

# Hybrid Pro Modular Kit 04

## HP-K-04

Hybrid Pro™ Modular exhibits and counters are a perfect solution for the serious exhibitor. Exhibits feature heavy-duty aluminum extrusion frames and push-fit fabric graphics. Count on making an unforgettable impact with Hybrid Pro Modular exhibit kits, counters, and accessories.



## features and benefits:

- Silver aluminum extrusion frame
- Single-sided SEG dye-sublimated push-fit fabric graphics
- Sheer graphic with velcro on perimeter
- UV graphic printed on 6mm white Sintra infills
- Kit includes frame, five fabric graphic panels, one sheer graphic, four white Sintra infills, and three molded OCH2 cases
- Lifetime hardware warranty against manufacturer defects

## dimensions:

### Hardware

Assembled unit:  
114.13" w x 94.5" h x 33.25" d  
2899mm(w) x 2400mm(h) x 845mm(d)

Approximate weight:  
341 lbs / 155 kg

### Graphic

Refer to related graphic templates for more information

<https://www.theexhibitorshandbook.com/download-graphic-templates>

### Shipping

Shipping dimensions - ships in 3 cases:  
3 OCH2 cases (each case): 52" l x 29" h x 15" d  
1321mm(l) x 737mm(h) x 381mm(d)

Approximate shipping weight (entire kit):  
431 lbs / 196 kg

## additional information:

Graphic material:  
Dye-sublimated fabric and UV printed on 6mm white Sintra infills



This product may include the following materials for recycle:  
aluminum, select wood, fabric, cardboard, paper, steel, and plastics.

We are continually improving and modifying our product range and reserve the right to vary the specifications without prior notice. All dimensions and weights quoted are approximate and we accept no responsibility for variance. E&OE. See Graphic Templates for graphic bleed specifications.

**R-HP-K-04**

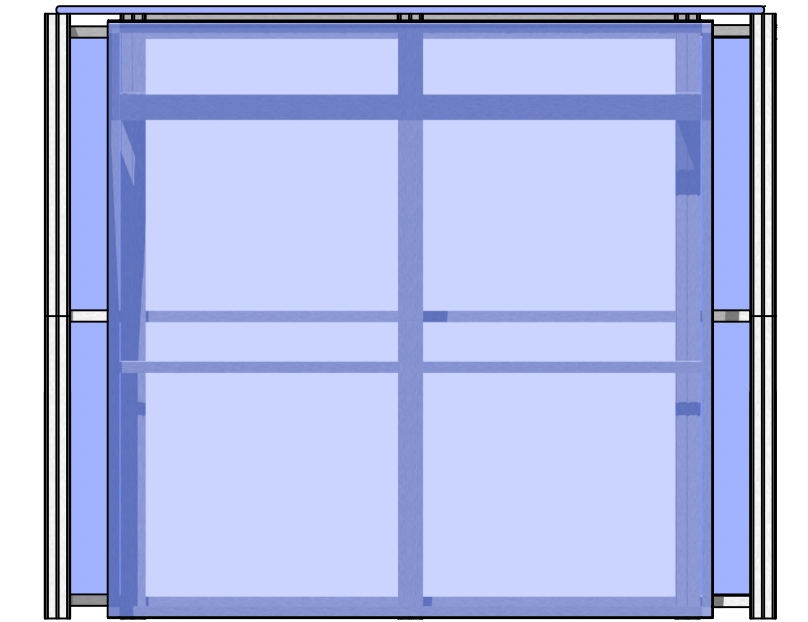
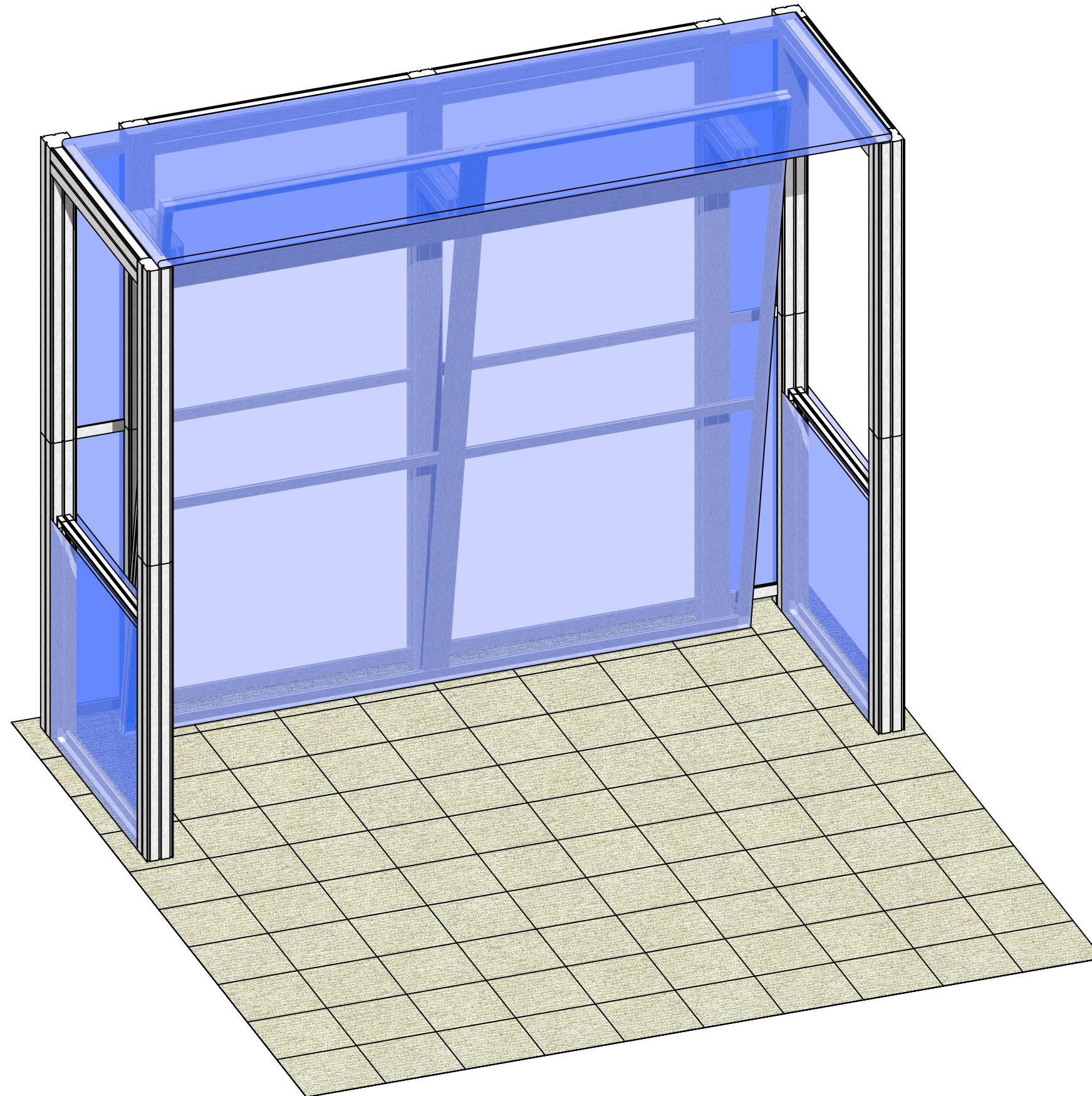

Code	#	Description
R15	14	1200MM (47.24") 100MM PM4S2 SQUARE EXTRUSION WITH PH2 STOP AT 165MM BOTH ENDS
R30	4	810MM (31.89") PHFC2 EXTRUSION WITH LOCKS 2 ENDS
R29	4	810MM (31.89") PHFC2 EXTRUSION WITH LOCKS 2 ENDS WITH SIDE CAM LOCKS
GRAPHIC A2	1	35.43"H X 35.43"W SINGLE SIDED DYESUB GRAPHIC W/FCE-2 ON PERIMETER
PM4 HINGE	3	90 DEG PM4 HINGE (POWDERCOATED 9006)
R36	3	300MM (11.81") 100MM PM4S2 SQUARE EXTRUSION WITH LOCKS 2 ENDS
R62	4	1000MM (39.37") PH EXTRUSION WITH LOCKS 2 ENDS
R34	2	1000MM (39.37") 100MM PM4S2 SQUARE EXTRUSION WITH LOCKS 2 ENDS
R35	2	900MM (35.43") 100MM PM4S2 SQUARE EXTRUSION WITH LOCKS 2 ENDS
R31	6	200MM (7.87") PH EXTRUSION WITH LOCKS 2 ENDS
R13	7	300MM (11.81") PM4D CONNECTOR WITH TENSION GLIDES
GRAPHIC B1	1	42.62"H X 7.87"W DSG GRAPHIC ON 6MM WHITE SINTRA - INFILL
GRAPHIC B2	1	42.62"H X 7.87"W DSG GRAPHIC ON 6MM WHITE SINTRA - INFILL
GRAPHIC B3	1	42.62"H X 7.87"W DSG GRAPHIC ON 6MM WHITE SINTRA - INFILL
GRAPHIC B4	1	42.62"H X 7.87"W DSG GRAPHIC ON 6MM WHITE SINTRA - INFILL
GRAPHIC A1	1	35.43"H X 35.43"W SINGLE SIDED DYESUB GRAPHIC W/FCE-2 ON PERIMETER
GRAPHIC A3	1	35.43"H X 35.43"W SINGLE SIDED DYESUB GRAPHIC W/FCE-2 ON PERIMETER
GRAPHIC A4	1	35.43"H X 35.43"W SINGLE SIDED DYESUB GRAPHIC W/FCE-2 ON PERIMETER
R38	2	1187MM PS2 EXTRUSION WITH LOCK 1 END - IB2 HOLE OTHER END
R33	2	1137MM (43.50") PS2 EXTRUSION WITH SLIDE LOCKS BOTH ENDS
IB2	6	PH INLINE CONNECTOR
GRAPHIC D	1	110 9/16" (H) X 39" (W) X 30MM TUBING - FABRIC STRUCTURE- ATTACHED USING TCH-30 CLAMPS
CB9-S	12	50MM SQUARE PHCF2 CORNER BRACKET
R28	8	1155MM (45.47") PHFC2 EXTRUSION WITH IB2 HOLE ONE SIDE-WITH LOCK 1 END
GRAPHIC C□□	1	94 1/2" (H) X 94 1/2" (W) SINGLE SIDED DYESUB GRAPHIC W/ FCE-2 (SEG) ON PERIMETER

# BOM

R-HP-K-04

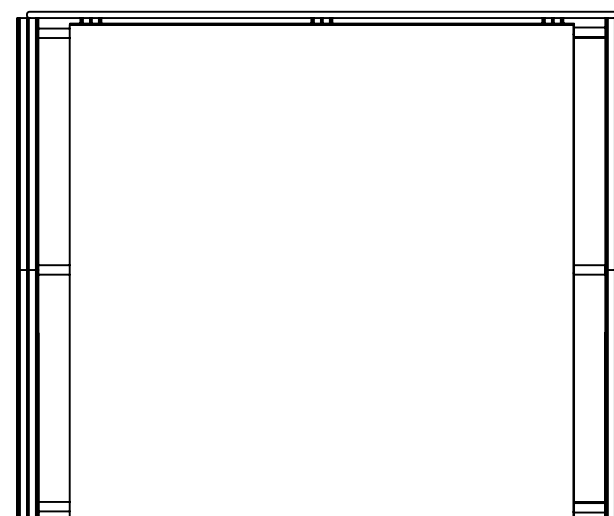
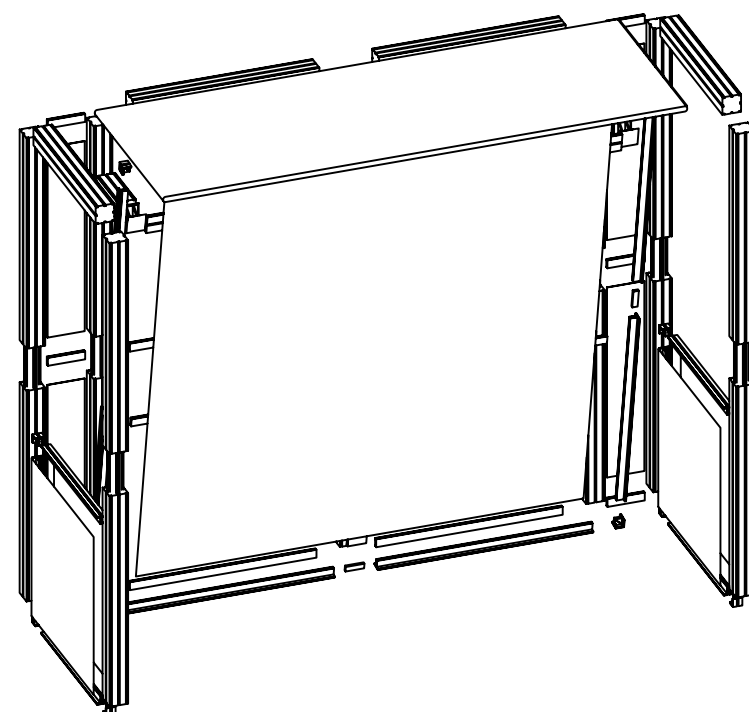
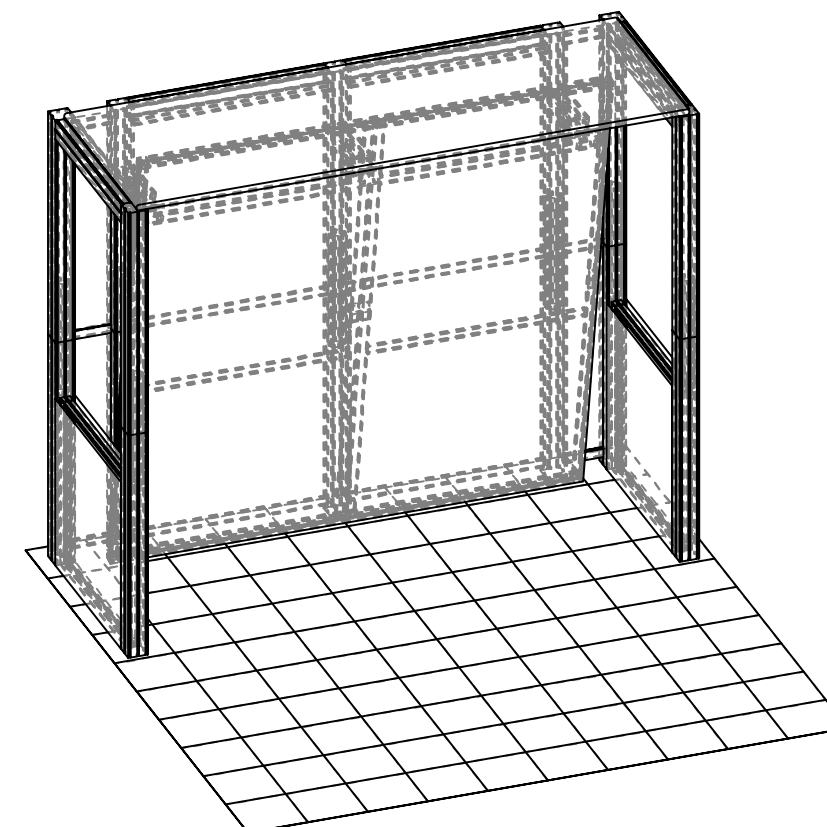
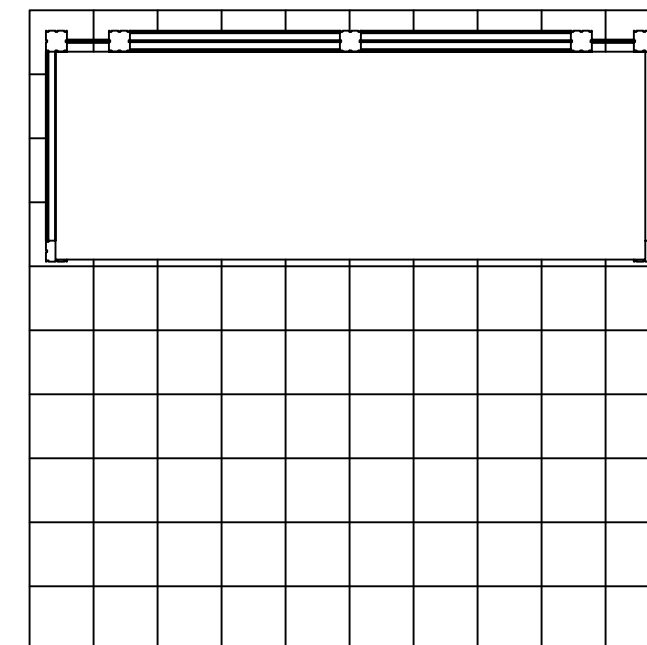

## SET-UP NOTES

1. Redesign of this exhibit without approval by Manufacturer may result in dangerous and unsafe structures. Manufacturer disclaims any responsibility for redesigned exhibits it does not approve in writing.
2. Parts and components such as panels and extrusions are manufactured to metric sizing. Where ever possible sizes have been noted in feet and inches as well as in metric. Below is the imperial to metric sizing table as reference. "Nominal" refers to approximate size.

### IMPERIAL TO METRIC SIZES

**8' Nominal = 94 1/2" or 2400mm Actual**  
**4' Nominal = 47 1/4" or 1200mm Actual**  
**3' Nominal = 35 7/16" or 900mm Actual**  
**2' Nominal = 23 5/8" or 600mm Actual**  
**1' Nominal = 11 13/16" or 300mm Actual**

1. Redesign of this exhibit without approval by manufacturer may result in dangerous and unsafe structures. Manufacturer disclaims any responsibility for redesigned exhibits it does not approve in writing.

2. Parts and components such as panels and extrusions are manufactured to metric sizing. Where ever possible sizes have been noted in feet and inches as well as in metric. Below is the imperial to metric sizing table as reference. "Nominal" refers to approximate size.

- |                    |                                   |
|--------------------|-----------------------------------|
| 2400mm = (94 1/2") | ☒ Phone Line / Fax                |
| 2100mm = (82 5/8") | ☒ Internet connection             |
| 1800mm = (70 7/8") | ☒ Outlet                          |
| 1500mm = (59")     | ☒ Main Drop (point of distrution) |
| 1200mm = (47 1/4") |                                   |
| 900mm = (35 1/2")  |                                   |
| 600mm = (23 5/8")  |                                   |
| 300mm = (11 7/8")  |                                   |
- Wire running under carpet

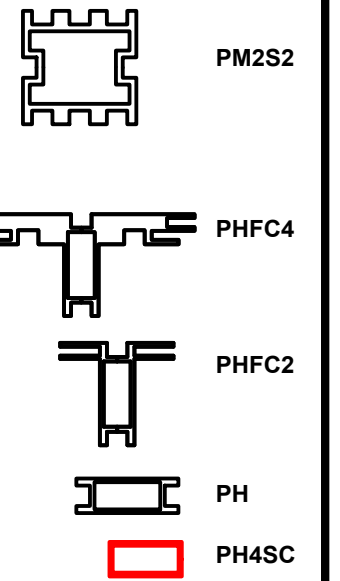
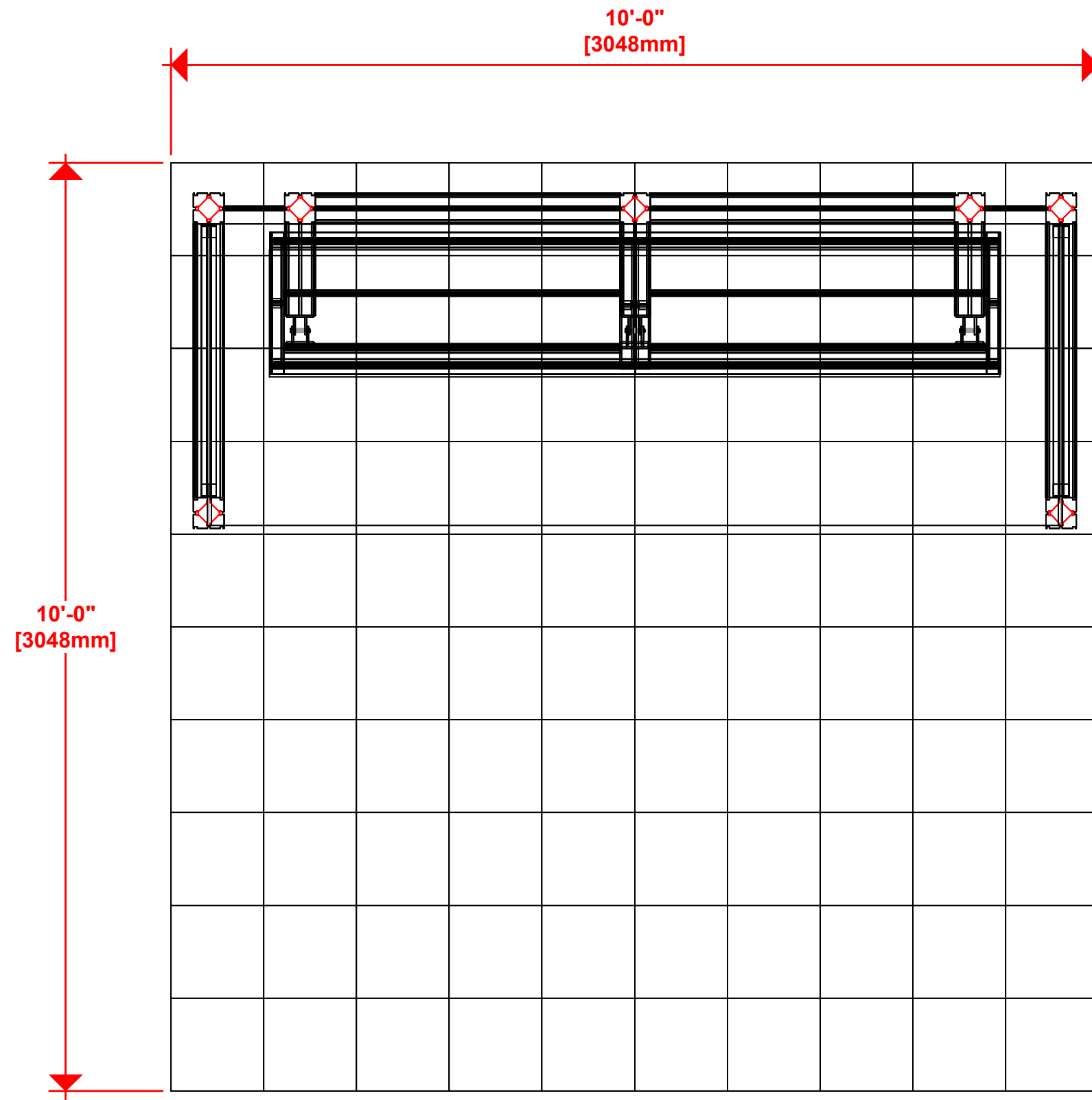

**HYBRID PRO RENTAL KIT**

Title: SET-UP INSTRUCTIONS

Code	#	Description
R30	4	810MM (31.89") PHFC2 EXTRUSION WITH LOCKS 2 ENDS
R29	4	810MM (31.89") PHFC2 EXTRUSION WITH LOCKS 2 ENDS WITH SIDE CAM LOCK
CB9-S	8	50MM SQUARE PHCF2 CORNER BRACKET

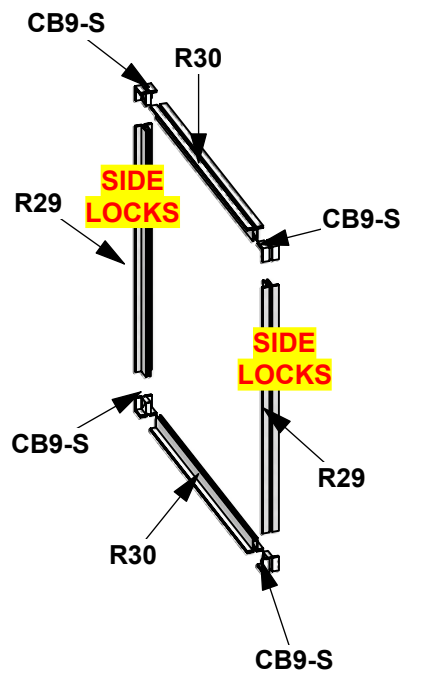
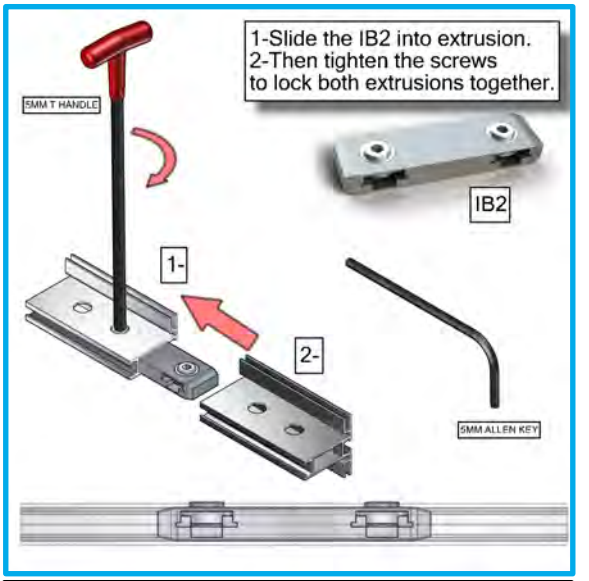
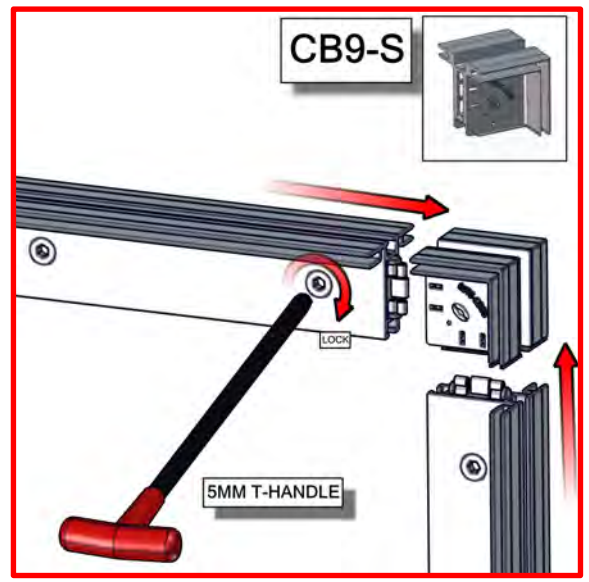

**BUILD 2 UNITS**

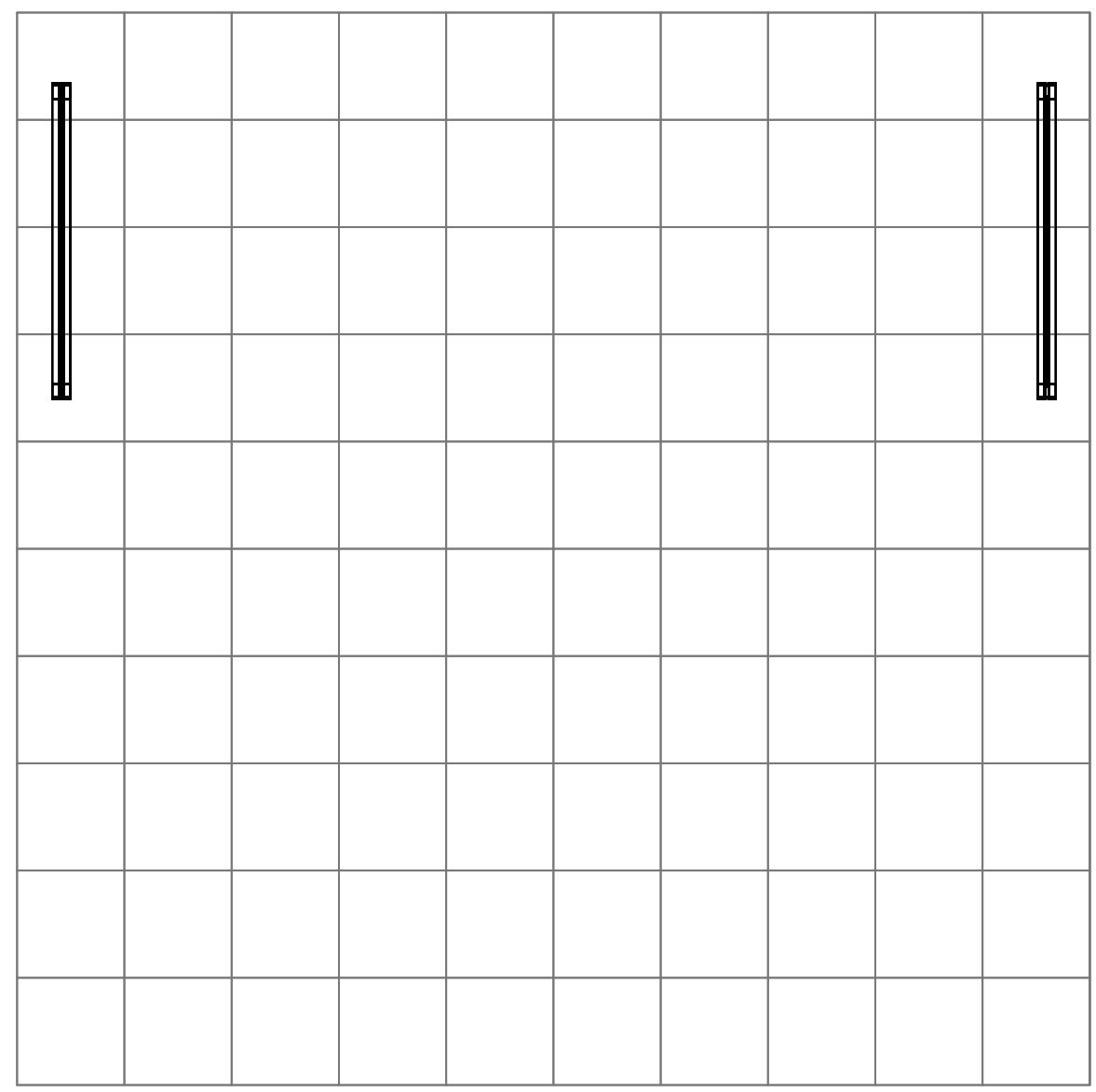

1. Redesign of this exhibit without approval by manufacturer may result in dangerous and unsafe structures. Manufacturer disclaims any responsibility for redesigned exhibits it does not approve in writing.

2. Parts and components such as panels and extrusions are manufactured to metric sizing. Where ever possible sizes have been noted in feet and inches as well as in metric. Below is the imperial to metric sizing table as reference. "Nominal" refers to approximate size.

2400mm = (94 1/2")	Phone Line / Fax
2100mm = (82 5/8")	Internet connection
1800mm = (70 7/8")	Outlet
1500mm = (59")	Main Drop (point of distrution)
1200mm = (47 1/4")	
900mm = (35 1/2")	
600mm = (23 5/8")	
300mm = (11 7/8")	

--- Wire running under carpet

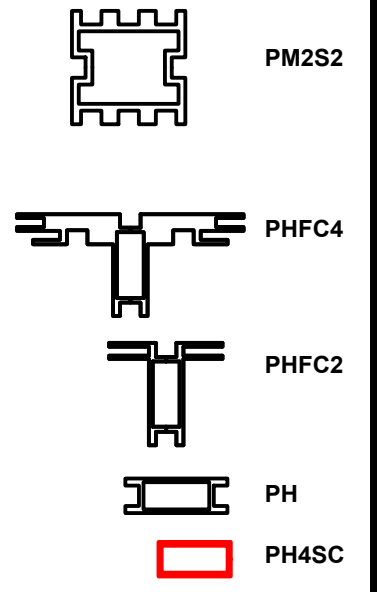

**HYBRID PRO RENTAL KIT**

Title: SET-UP INSTRUCTIONS

Code	#	Description
R15	5	1200MM (47.24") 100MM PM4S2 SQUARE EXTRUSION WITH PH2 STOP AT 165MM BO
R62	2	1000MM (39.37") PH EXTRUSION WITH LOCKS 2 ENDS
R31	2	200MM (7.87") PH EXTRUSION WITH LOCKS 2 ENDS
GRAPHIC B2	1	42.62"H X 7.87"W DSG GRAPHIC ON 6MM WHITE SINTRA - INFILL
GRAPHIC B4	1	42.62"H X 7.87"W DSG GRAPHIC ON 6MM WHITE SINTRA - INFILL

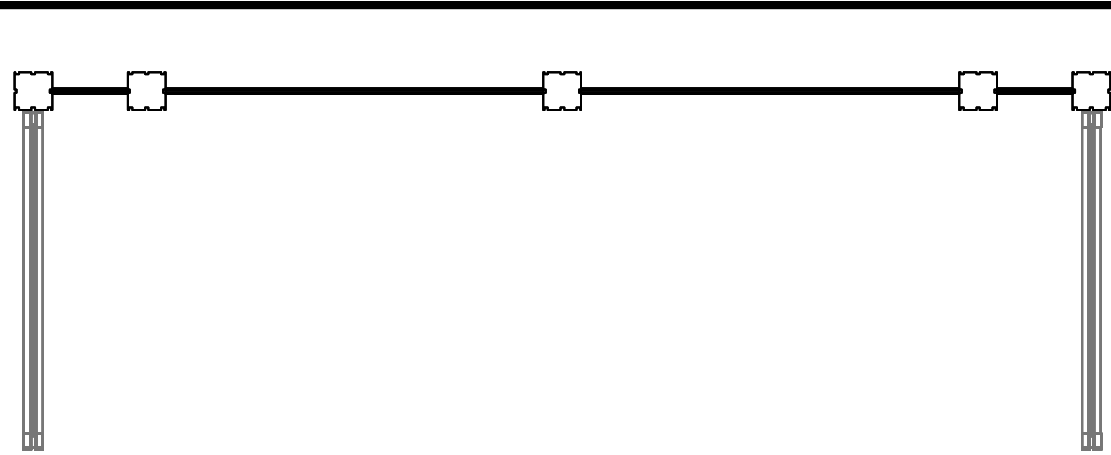
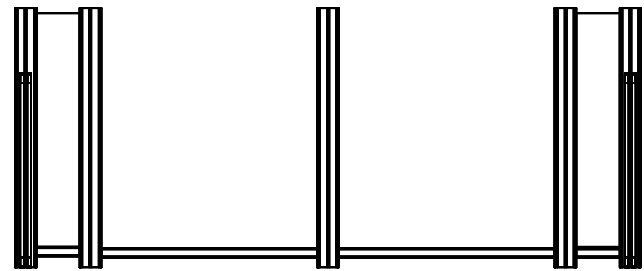

1. Redesign of this exhibit without approval by manufacturer may result in dangerous and unsafe structures. Manufacturer disclaims any responsibility for redesigned exhibits it does not approve in writing.

2. Parts and components such as panels and extrusions are manufactured to metric sizing. Where ever possible sizes have been noted in feet and inches as well as in metric. Below is the imperial to metric sizing table as reference. "Nominal" refers to approximate size.

2400mm = (94 1/2")	Phone Line / Fax
2100mm = (82 5/8")	Internet connection
1800mm = (70 7/8")	Outlet
1500mm = (59")	Main Drop (point of distrution)
1200mm = (47 1/4")	
900mm = (35 1/2")	
600mm = (23 5/8")	
300mm = (11 7/8")	

--- Wire running under carpet

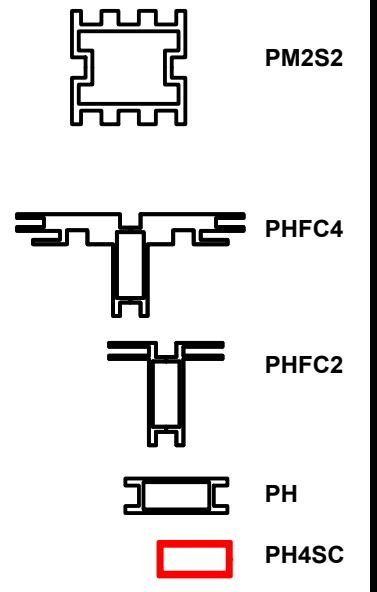
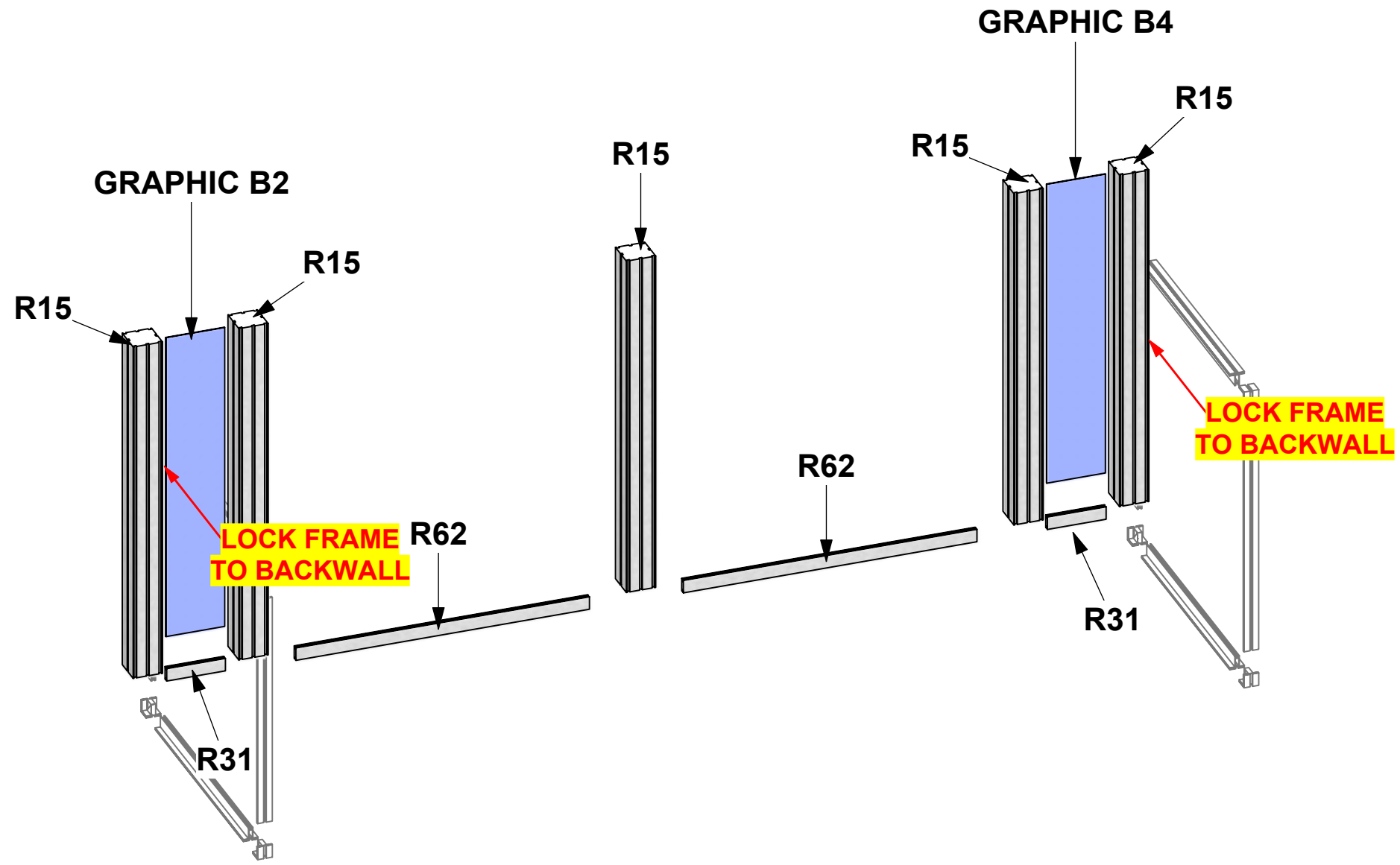
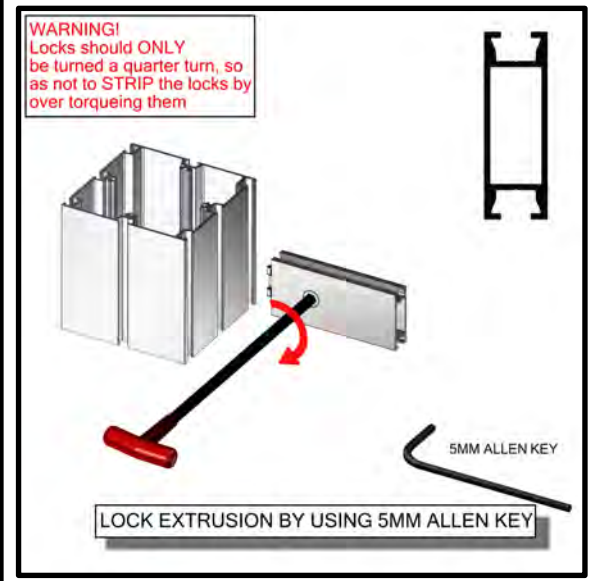

HYBRID PRO RENTAL KIT

Title: SET-UP INSTRUCTIONS

Code	#	Description
R62	2	1000MM (39.37") PH EXTRUSION WITH LOCKS 2 ENDS
R13	5	300MM (11.81") PM4D CONNECTOR WITH TENSION GLIDES
R31	2	200MM (7.87") PH EXTRUSION WITH LOCKS 2 ENDS

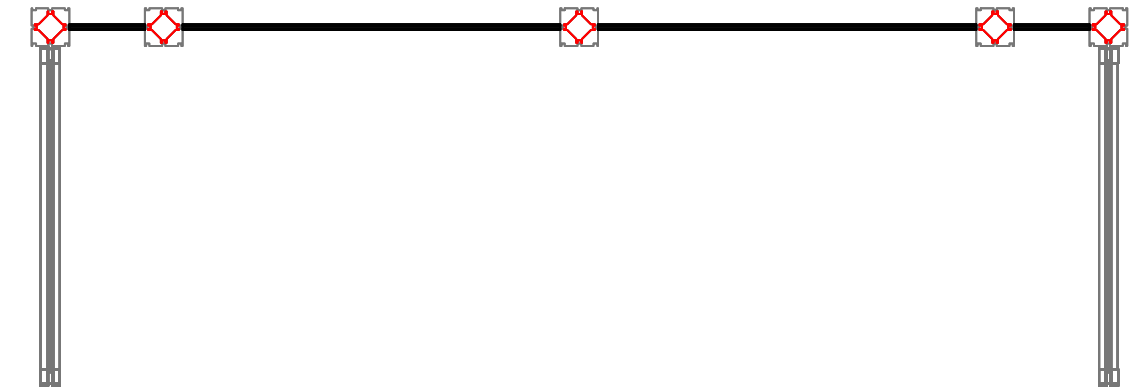
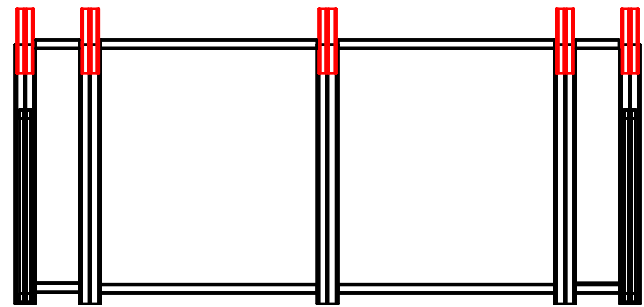

**WARNING!**  
Locks should ONLY be turned a quarter turn, so as not to STRIP the locks by over torquing them

5MM ALLEN KEY

LOCK EXTRUSION BY USING 5MM ALLEN KEY

**PM4D CONNECTOR**

TENSION GLIDES

STOP

1- Slide the PM4D CONNECTOR into the POST until it rests on the PM4D Stop.

2- Then slide the top POST onto the PM4D CONNECTOR.

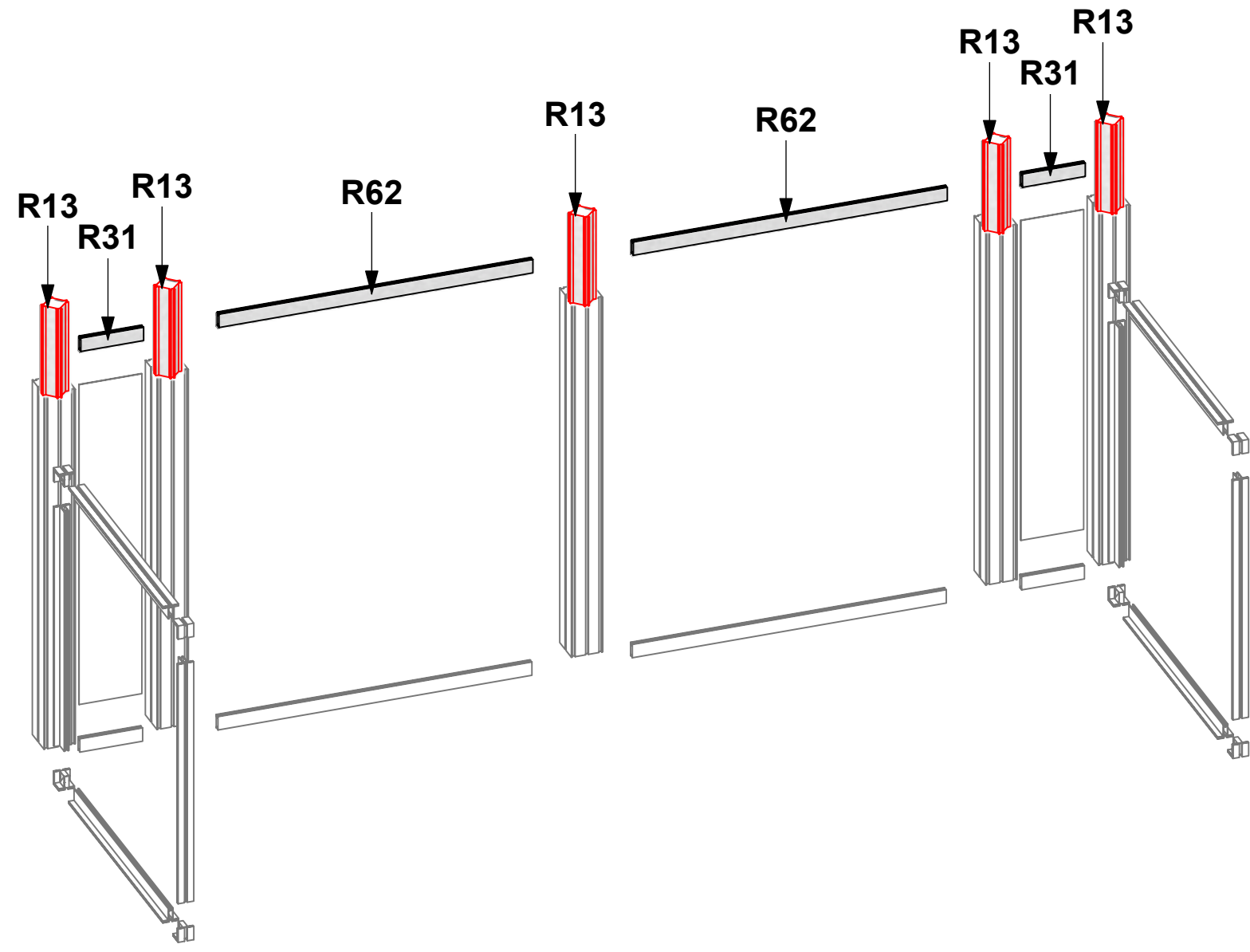

1. Redesign of this exhibit without approval by manufacturer may result in dangerous and unsafe structures. Manufacturer disclaims any responsibility for redesigned exhibits it does not approve in writing.

2. Parts and components such as panels and extrusions are manufactured to metric sizing. Where ever possible sizes have been noted in feet and inches as well as in metric. Below is the imperial to metric sizing table as reference. "Nominal" refers to approximate size.

2400mm = (94 1/2")	Phone Line / Fax
2100mm = (82 5/8")	Internet connection
1800mm = (70 7/8")	Outlet
1500mm = (59")	Main Drop (point of distrution)
1200mm = (47 1/4")	
900mm = (35 1/2")	
600mm = (23 5/8")	
300mm = (11 7/8")	

--- Wire running under carpet

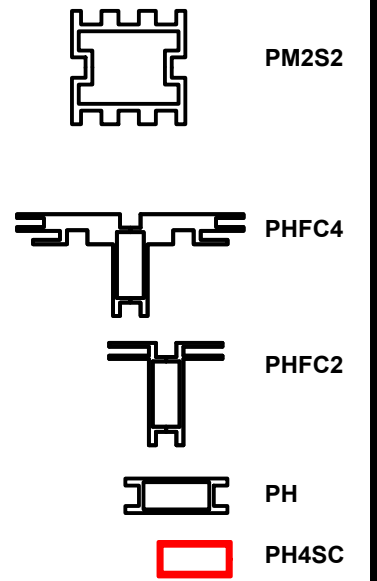

**HYBRID PRO RENTAL KIT**

Title: SET-UP INSTRUCTIONS



Code	#	Description
R34	2	1000MM (39.37") 100MM PM4S2 SQUARE EXTRUSION WITH LOCKS 2 ENDS
R31	2	200MM (7.87") PH EXTRUSION WITH LOCKS 2 ENDS
R15	5	1200MM (47.24") 100MM PM4S2 SQUARE EXTRUSION WITH PH2 STOP AT 165MM B
GRAPHIC B1	1	42.62"H X 7.87"W DSG GRAPHIC ON 6MM WHITE SINTRA - INFILL
GRAPHIC B3	1	42.62"H X 7.87"W DSG GRAPHIC ON 6MM WHITE SINTRA - INFILL

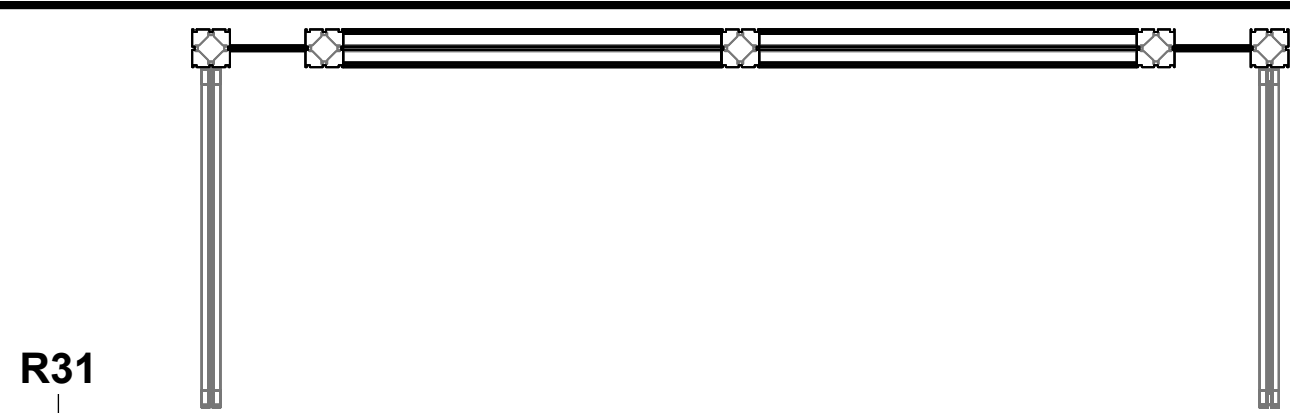
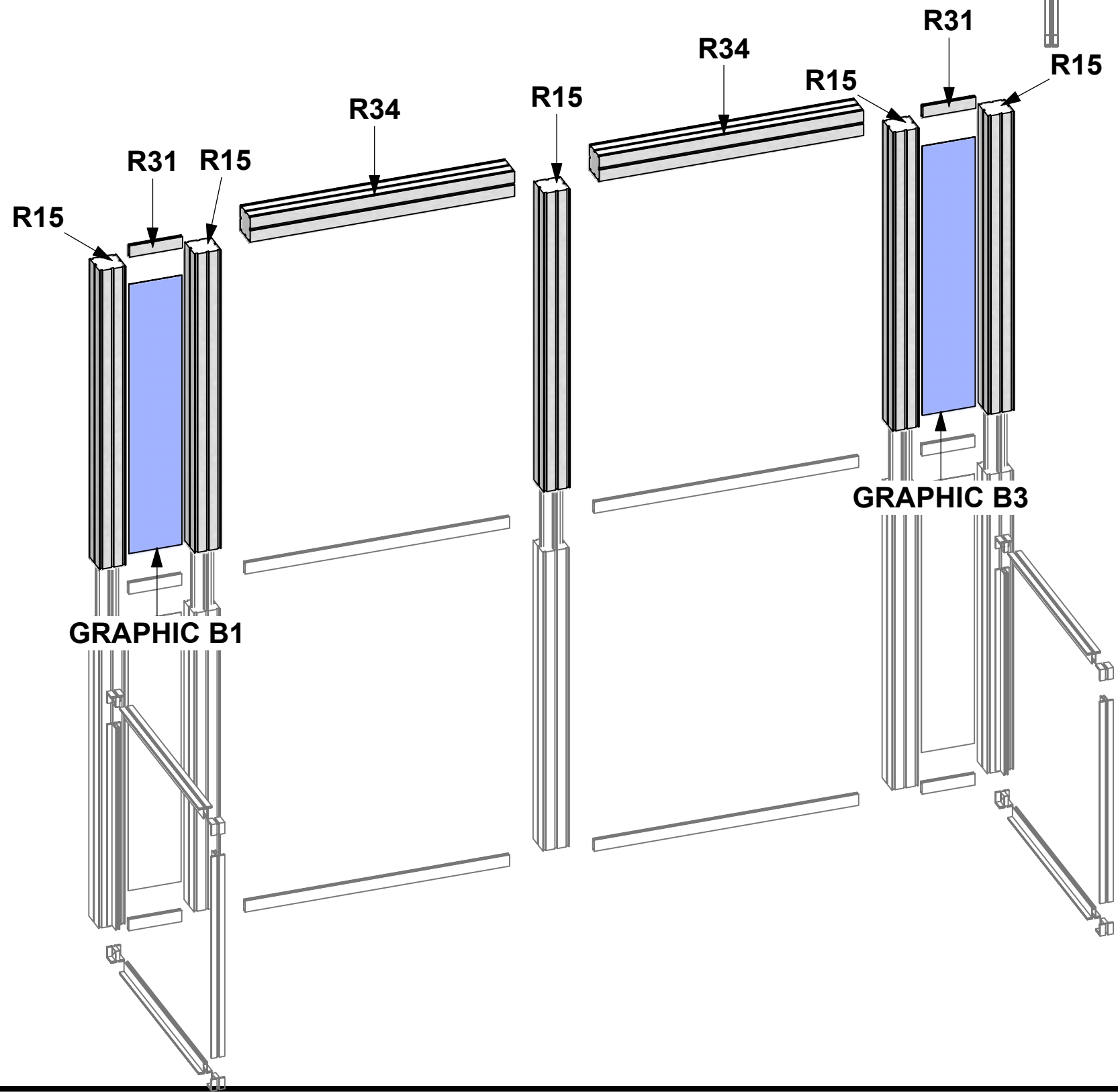

1. Redesign of this exhibit without approval by manufacturer may result in dangerous and unsafe structures. Manufacturer disclaims any responsibility for redesigned exhibits it does not approve in writing.

2. Parts and components such as panels and extrusions are manufactured to metric sizing. Where ever possible sizes have been noted in feet and inches as well as in metric. Below is the imperial to metric sizing table as reference. "Nominal" refers to approximate size.

2400mm = (94 1/2")	Phone Line / Fax
2100mm = (82 5/8")	Internet connection
1800mm = (70 7/8")	Outlet
1500mm = (59")	Main Drop (point of distrution)
1200mm = (47 1/4")	
900mm = (35 1/2")	
600mm = (23 5/8")	
300mm = (11 7/8")	

--- Wire running under carpet

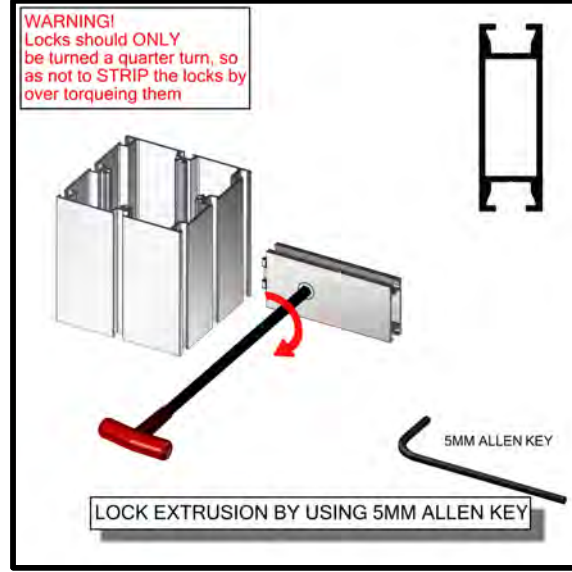
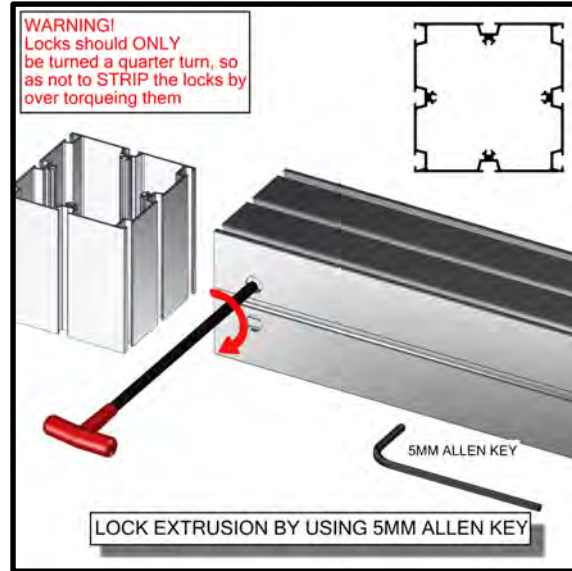
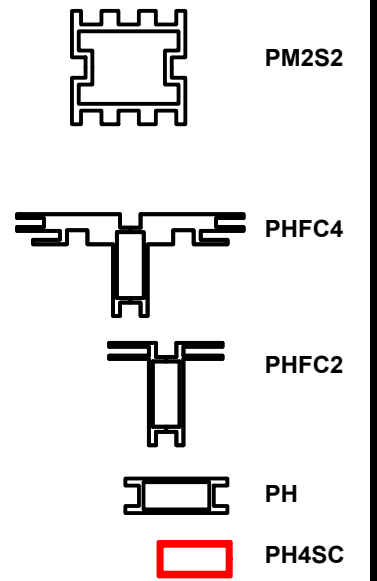

**HYBRID PRO RENTAL KIT**

Title: SET-UP INSTRUCTIONS

Code	#	Description
R15	4	1200MM (47.24") 100MM PM4S2 SQUARE EXTRUSION
R35	2	900MM (35.43") 100MM PM4S2 SQUARE EXTRUSION
R13	2	300MM (11.81") PM4D CONNECTOR WITH TENSION GLIDES

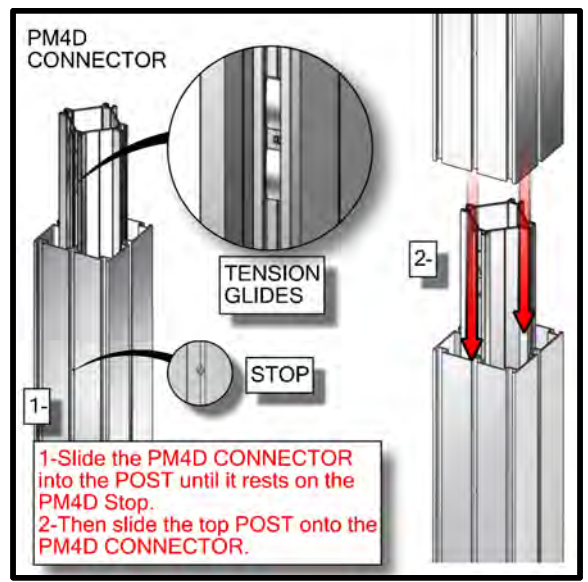
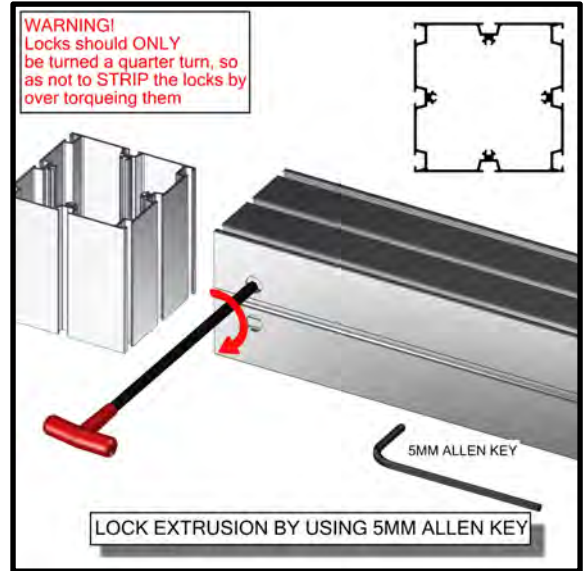
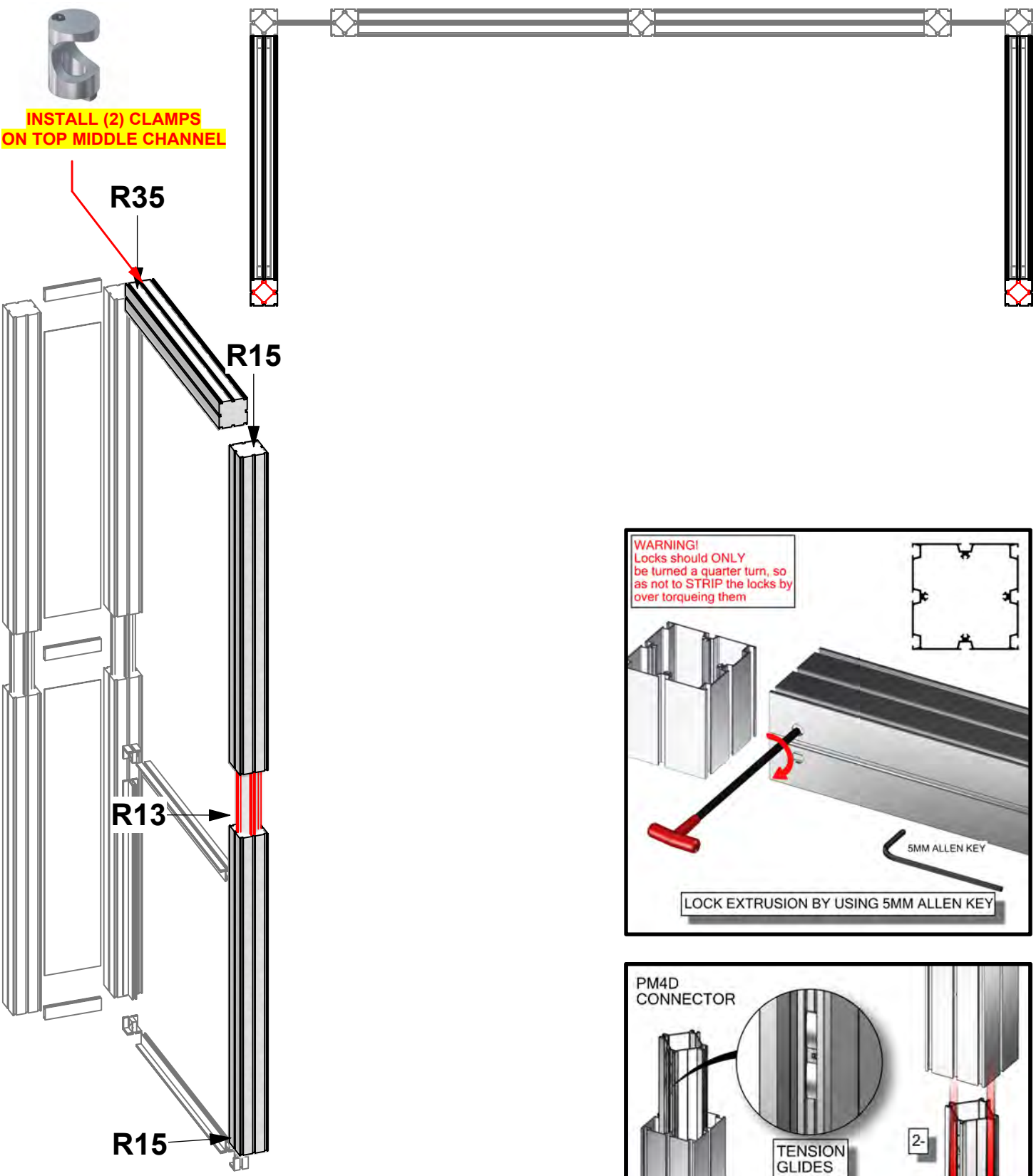
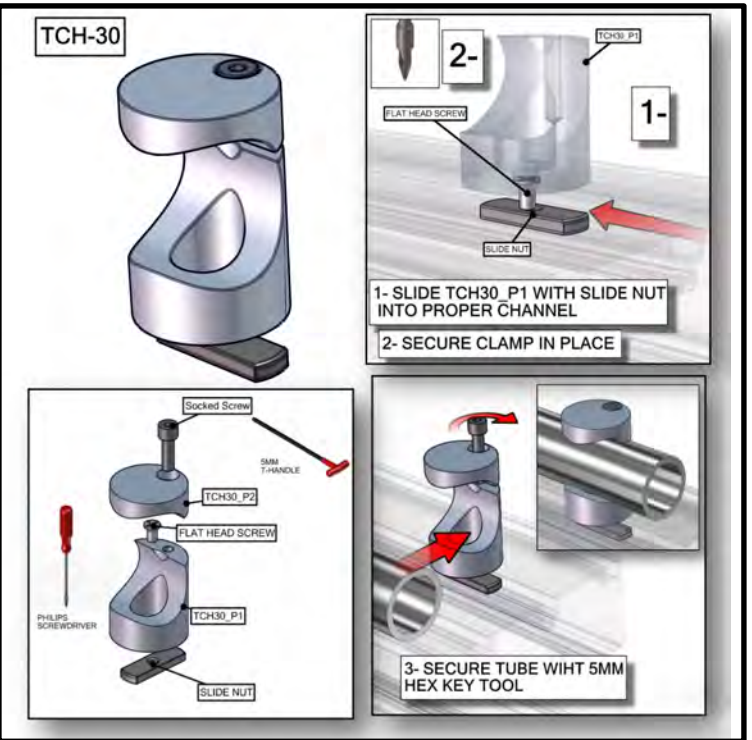
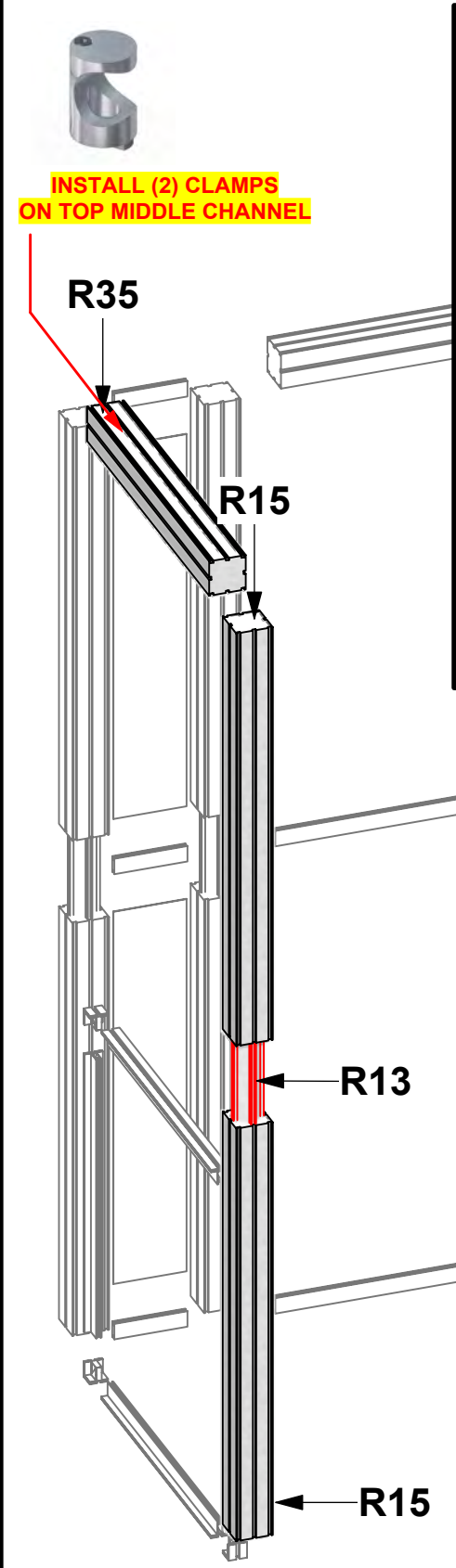

1. Redesign of this exhibit without approval by manufacturer may result in dangerous and unsafe structures. Manufacturer disclaims any responsibility for redesigned exhibits it does not approve in writing.

2. Parts and components such as panels and extrusions are manufactured to metric sizing. Where ever possible sizes have been noted in feet and inches as well as in metric. Below is the imperial to metric sizing table as reference. "Nominal" refers to approximate size.

2400mm = (94 1/2")	Phone Line / Fax
2100mm = (82 5/8")	Internet connection
1800mm = (70 7/8")	Outlet
1500mm = (59")	Main Drop (point of distrution)
1200mm = (47 1/4")	
900mm = (35 1/2")	
600mm = (23 5/8")	
300mm = (11 7/8")	

--- Wire running under carpet

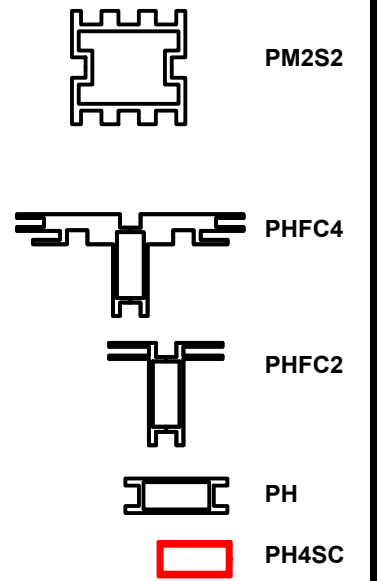

**HYBRID PRO RENTAL KIT**

Title: SET-UP INSTRUCTIONS

Code	#	Description
GRAPHIC A2	1	35.43"H X 35.43"W SINGLE SIDED DYESUB GRAPHIC W/FCE-2 ON PERIMETER
GRAPHIC A1	1	35.43"H X 35.43"W SINGLE SIDED DYESUB GRAPHIC W/FCE-2 ON PERIMETER
GRAPHIC A3	1	35.43"H X 35.43"W SINGLE SIDED DYESUB GRAPHIC W/FCE-2 ON PERIMETER
GRAPHIC A4	1	35.43"H X 35.43"W SINGLE SIDED DYESUB GRAPHIC W/FCE-2 ON PERIMETER

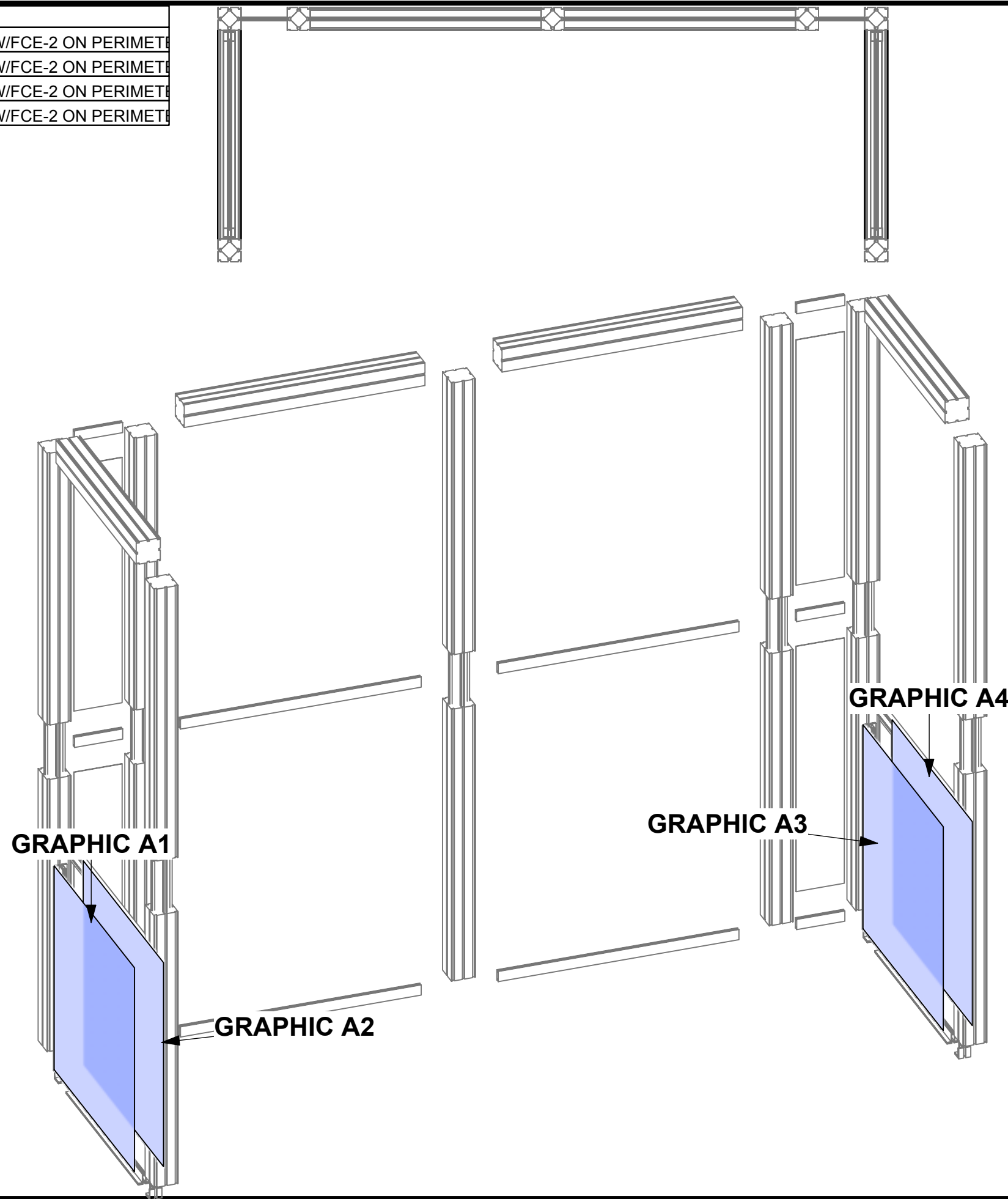
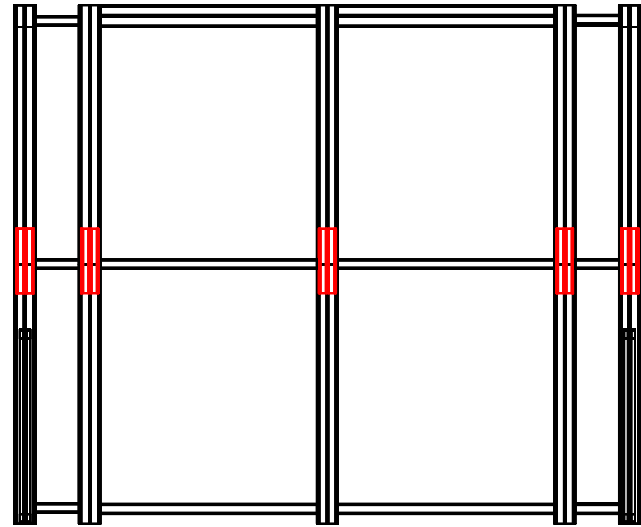

1. Redesign of this exhibit without approval by manufacturer may result in dangerous and unsafe structures. Manufacturer disclaims any responsibility for redesigned exhibits it does not approve in writing.

2. Parts and components such as panels and extrusions are manufactured to metric sizing. Where ever possible sizes have been noted in feet and inches as well as in metric. Below is the imperial to metric sizing table as reference. "Nominal" refers to approximate size.

- 2400mm = (94 1/2") Phone Line / Fax
  - 2100mm = (82 5/8") Internet connection
  - 1800mm = (70 7/8")
  - 1500mm = (59")
  - 1200mm = (47 1/4")
  - 900mm = (35 1/2")
  - 600mm = (23 5/8")
  - 300mm = (11 7/8")
- Outlet
- Main Drop (point of distrution)
- Wire running under carpet

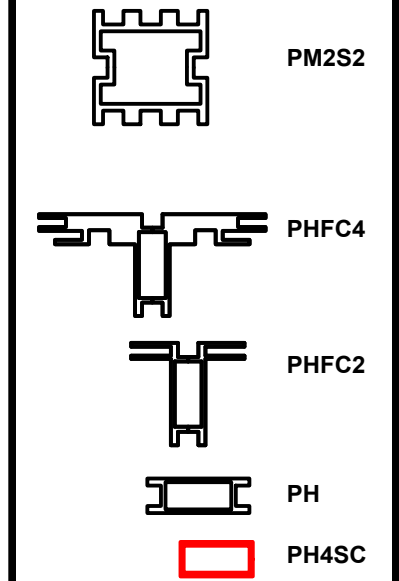

**HYBRID PRO RENTAL KIT**

Title: SET-UP INSTRUCTIONS

Code	#	Description
PM4 HINGE	3	90 DEG PM4 HINGE (POWDERCOATED 9006)
R36	3	300MM (11.81") 100MM PM4S2 SQUARE EXTRUSION WITH LOCKS 2 ENDS
R38	2	1187MM PS2 EXTRUSION WITH LOCK 1 END - IB2 HOLE OTHER END
R33	2	1137MM ) PS2 EXTRUSION WITH SLIDE LOCKS BOTH ENDS
IB2	6	PH INLINE CONNECTOR
CB9-S	4	50MM SQUARE PHCF2 CORNER BRACKET
R28	8	1155MM (45.47") PHFC2 EXTRUSION WITH IB2 HOLE ONE SIDE-WITH LOCK 1 END

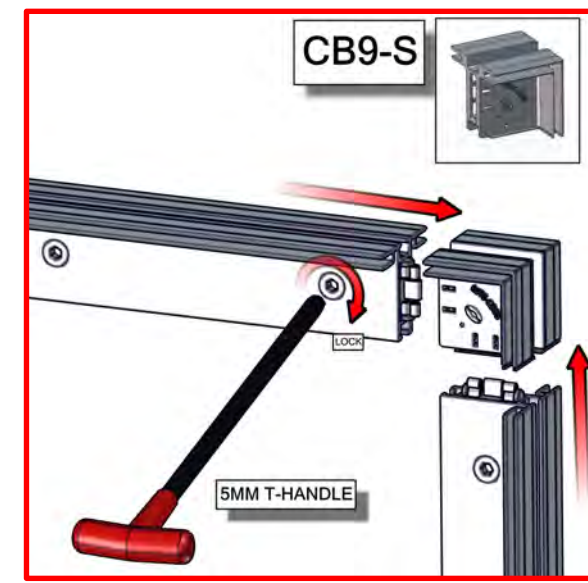
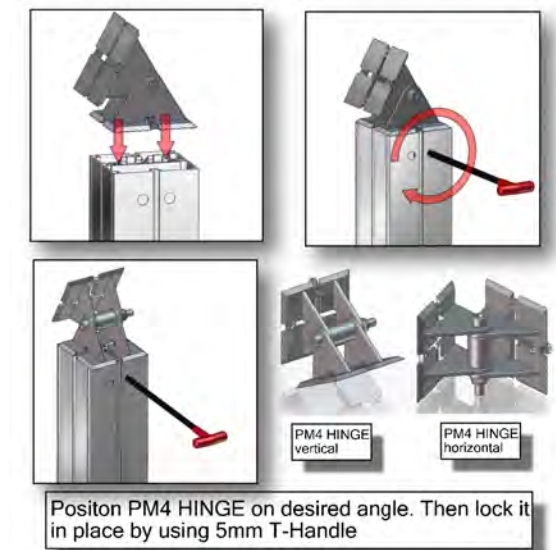
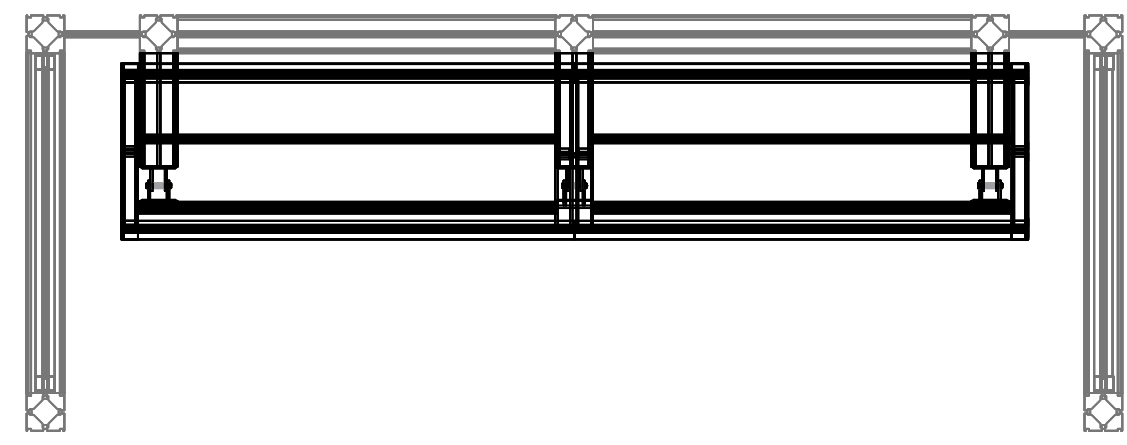
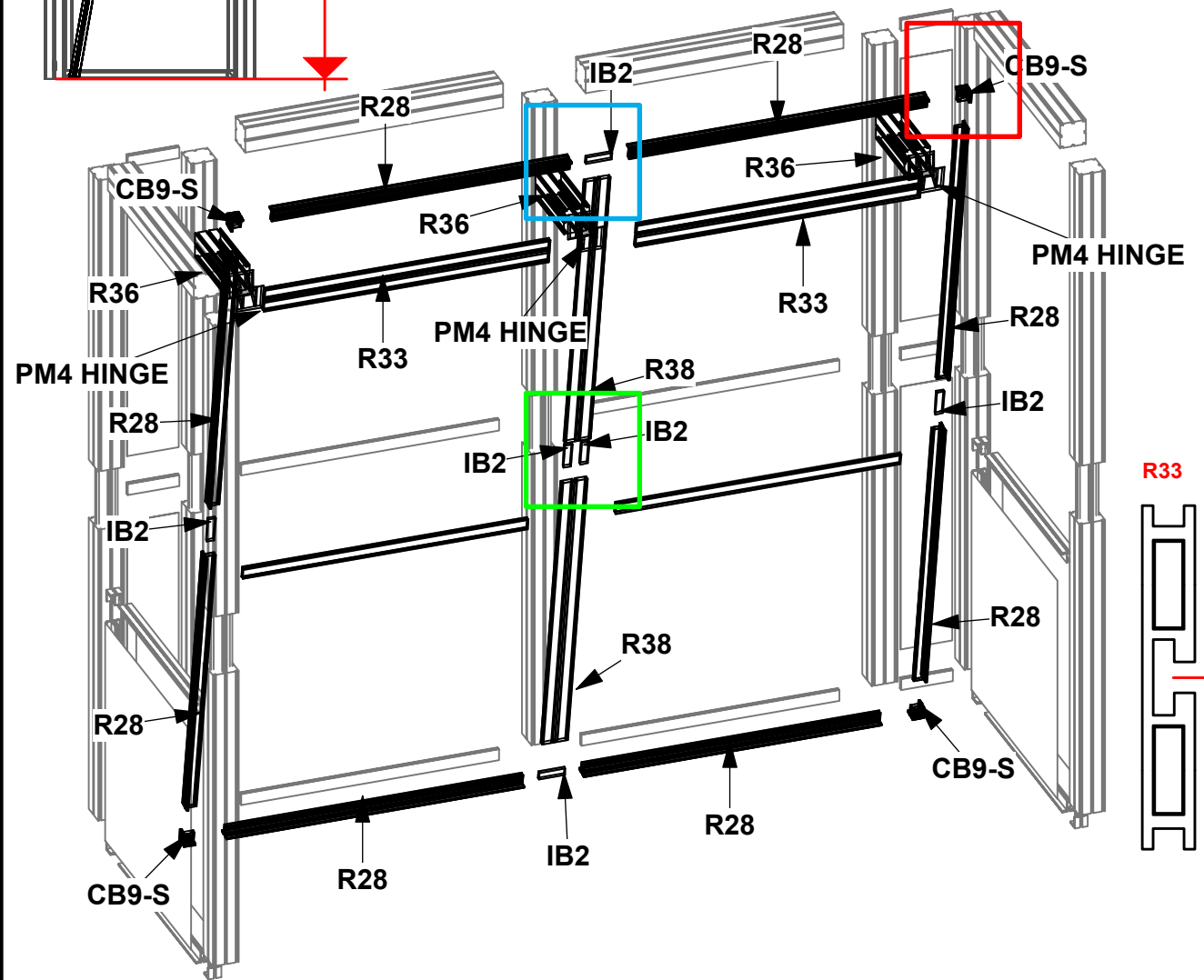
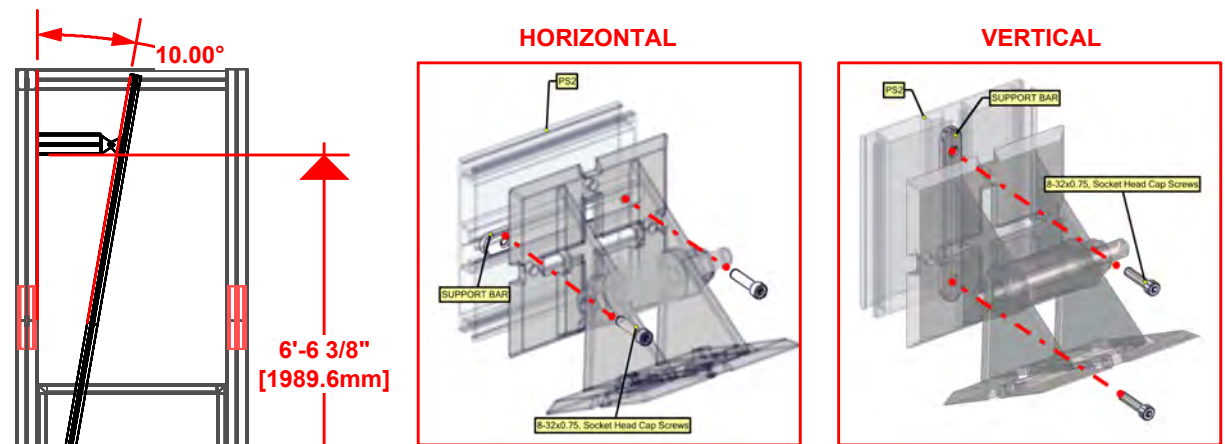

1. Redesign of this exhibit without approval by manufacturer may result in dangerous and unsafe structures. Manufacturer disclaims any responsibility for redesigned exhibits it does not approve in writing.

2. Parts and components such as panels and extrusions are manufactured to metric sizing. Where ever possible sizes have been noted in feet and inches as well as in metric. Below is the imperial to metric sizing table as reference. "Nominal" refers to approximate size.

2400mm = (94 1/2")  
2100mm = (82 5/8")  
1800mm = (70 7/8")  
1500mm = (59")  
1200mm = (47 1/4")  
900mm = (35 1/2")  
600mm = (23 5/8")  
300mm = (11 7/8")

Phone Line / Fax  
Internet connection  
Outlet  
Main Drop (point of distrution)  
Wire running under carpet

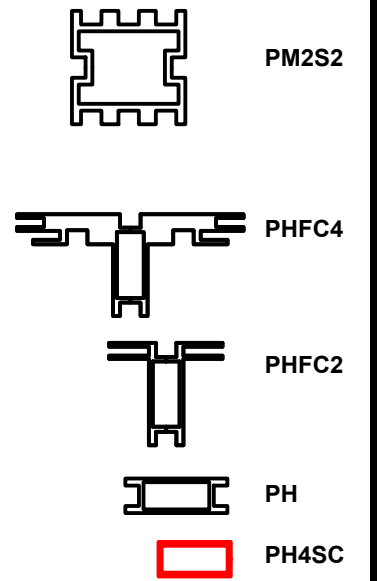

HYBRID PRO RENTAL KIT

Title: SET-UP INSTRUCTIONS

THE CROSS SUPPORTS ARE IN THE BACK CHANEL TO ACOMADATE THE LIGHT

Code	#	Description
GRAPHIC C□□	1	94 1/2" (H) X 94 1/2" (W) SINGLE SIDED DYESUB GRAPHIC W/ FCE-2 (SE

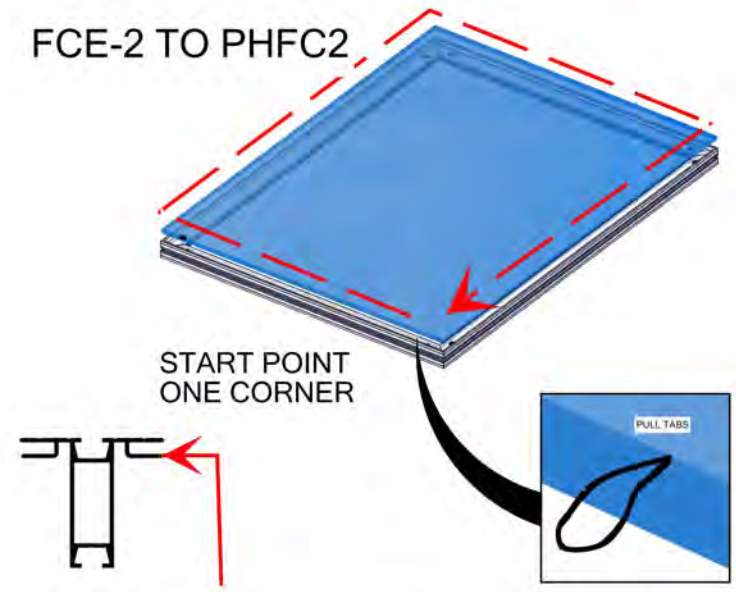
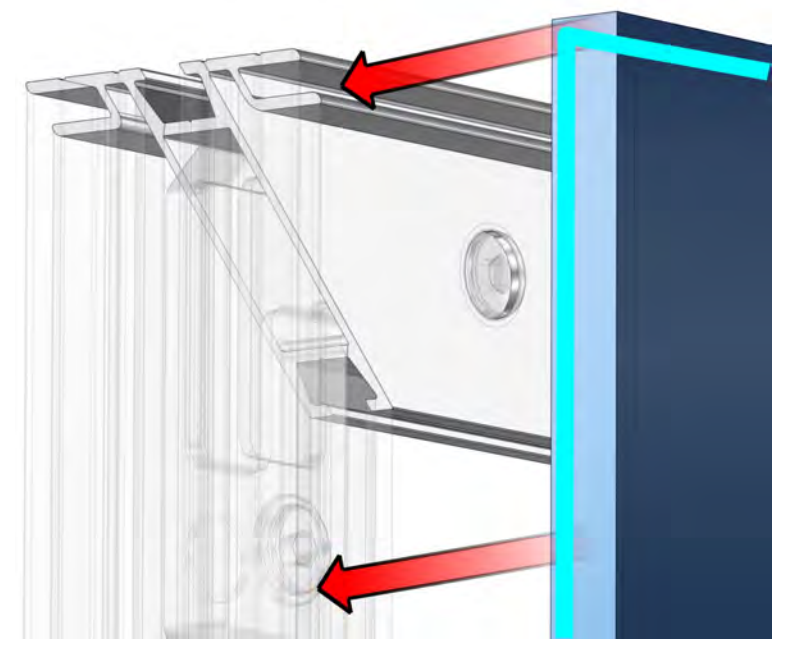
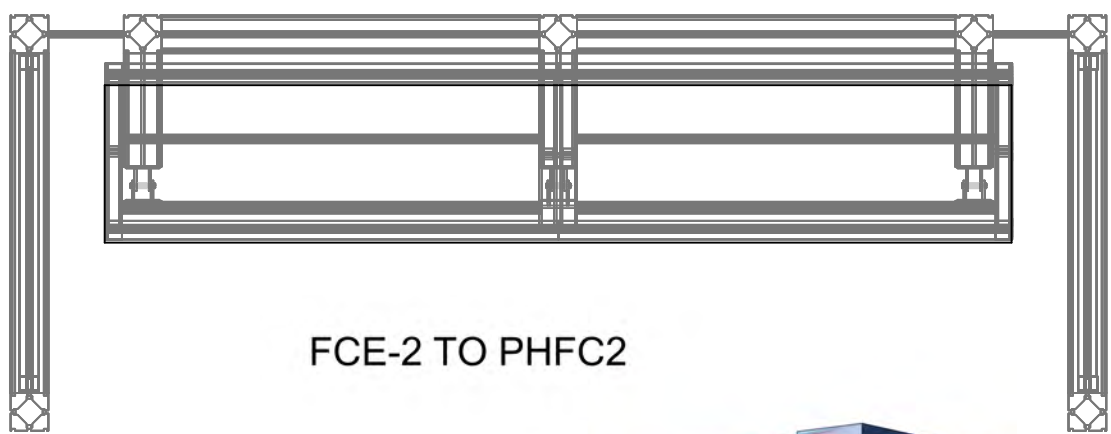
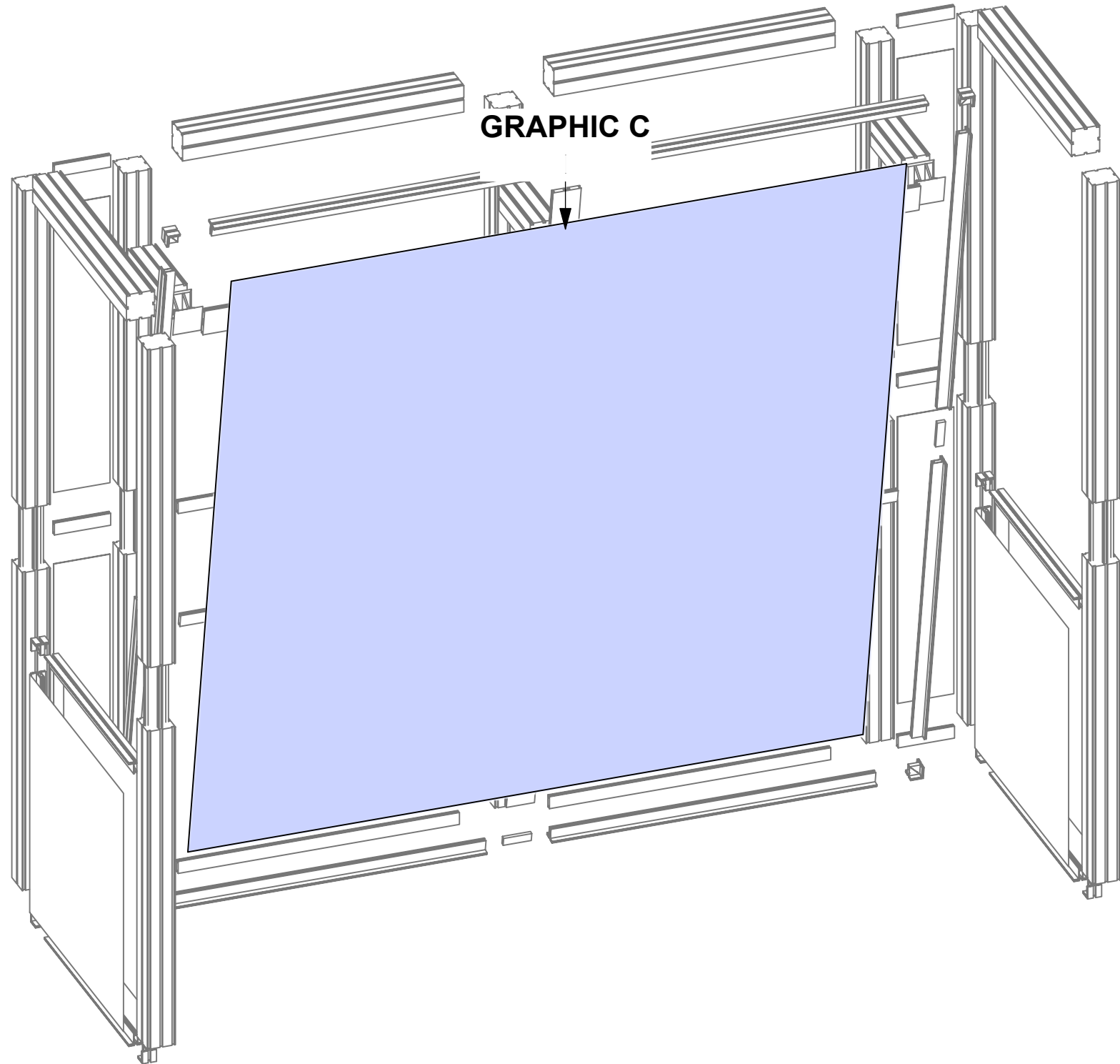

Install graphic by pressing the FCE-2 into the channels of PHFC2 extrusion. To pull graphics out of the channels, use tabs on the front side

1. Redesign of this exhibit without approval by manufacturer may result in dangerous and unsafe structures. Manufacturer disclaims any responsibility for redesigned exhibits it does not approve in writing.

2. Parts and components such as panels and extrusions are manufactured to metric sizing. Where ever possible sizes have been noted in feet and inches as well as in metric. Below is the imperial to metric sizing table as reference. "Nominal" refers to approximate size.

2400mm = (94 1/2")	☒ Phone Line / Fax
2100mm = (82 5/8")	☒ Internet connection
1800mm = (70 7/8")	☒ Outlet
1500mm = (59")	☒ Main Drop (point of distrution)
1200mm = (47 1/4")	
900mm = (35 1/2")	
600mm = (23 5/8")	
300mm = (11 7/8")	

--- Wire running under carpet

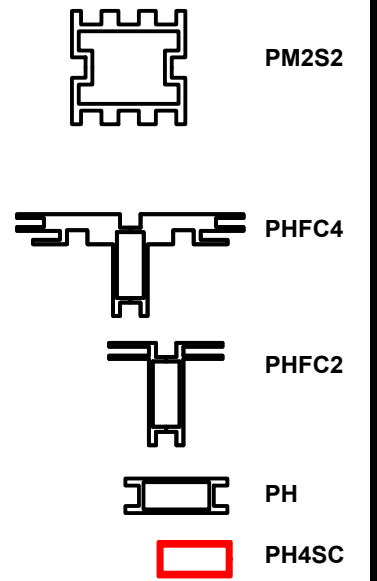

**HYBRID PRO RENTAL KIT**

Title: SET-UP INSTRUCTIONS

**SET UP INSTRUCTIONS:**

1. CONNECT BOTTOM AND TOP RAILS FOLLOWING THE LABELS
2. CONNECT SIDE RAILS
3. CLEAN THE FRAME AND PLACE THEM ON CLEAN PLACE
4. CAREFULLY REMOVE FABRIC COVER FROM BAGS
5. PLACE COVER AROUND THE BOTTOM OF THE FRAME
6. PULL COVER CAREFULLY UP TO THE TOP
7. CLOSE ALL ZIPPERS
8. ADJUST FABRIC AROUND THE FRAME

**BREAK DOWN INSTRUCTIONS:**

REVERSE SET-UP STEPS TO BREAKDOWN FRAME

**FABRIC CARE INSTRUCTIONS:**

1. UNZIP COVER ZIPPERS
2. CAREFULLY REMOVE FABRIC COVER
3. CLOSE ALL ZIPPERS
4. FOLD OR ROLL NEATLY
5. PLACE FABRIC IN COVER BAG

**PART LIST:**

- PER UNIT
- 7 30MM DIA. TUBE SECTIONS
  - 8 ES-30 EXPANDING SPIGOT
  - 1 2.5MM HEX KEY
  - 4 TCH-30
  - 1 FABRIC COVER

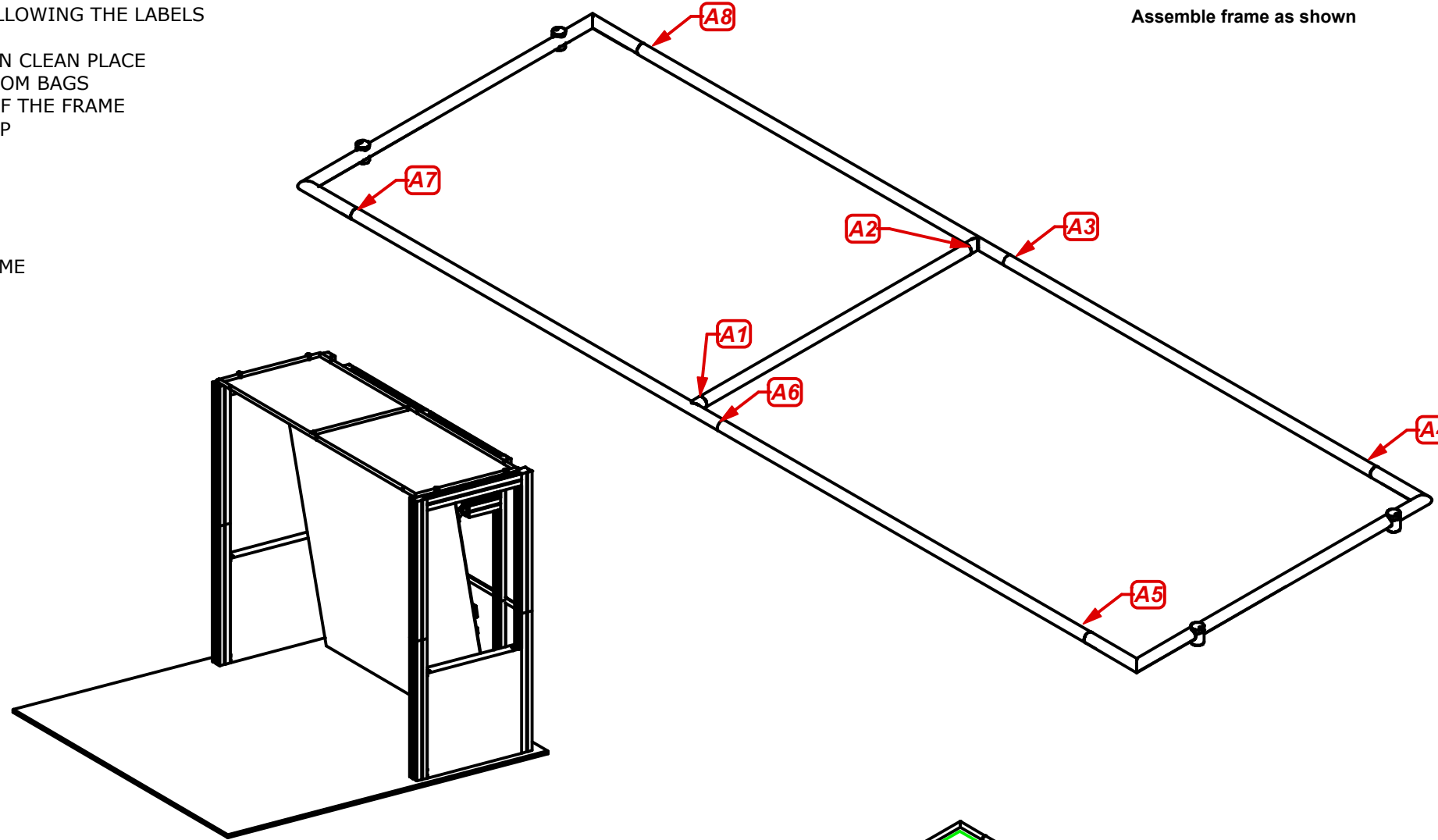

**Frame 'A' Assembly**

Assemble frame as shown

1. Redesign of this exhibit without approval by manufacturer may result in dangerous and unsafe structures. Manufacturer disclaims any responsibility for redesigned exhibits it does not approve in writing.

2. Parts and components such as panels and extrusions are manufactured to metric sizing. Where ever possible sizes have been noted in feet and inches as well as in metric. Below is the imperial to metric sizing table as reference. "Nominal" refers to approximate size.

2400mm = (94 1/2")	Phone Line / Fax
2100mm = (82 5/8")	Internet connection
1800mm = (70 7/8")	Outlet
1500mm = (59")	Main Drop (point of distrution)
1200mm = (47 1/4")	
900mm = (35 1/2")	
600mm = (23 5/8")	
300mm = (11 7/8")	

--- Wire running under carpet ---

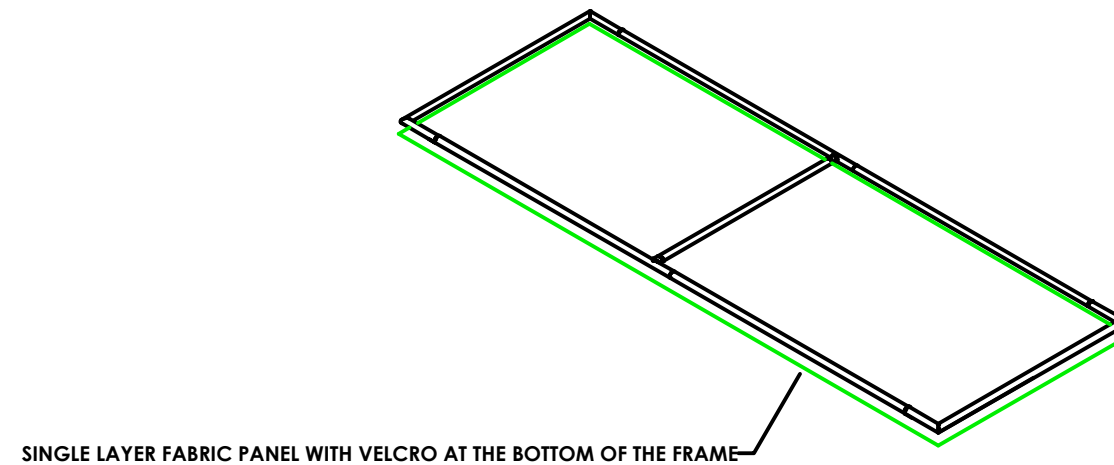
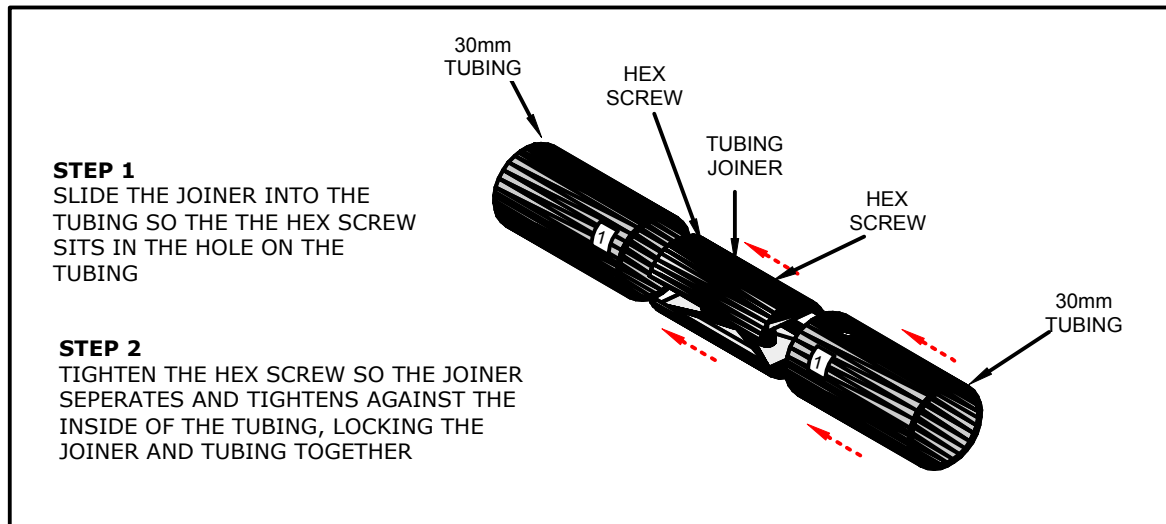
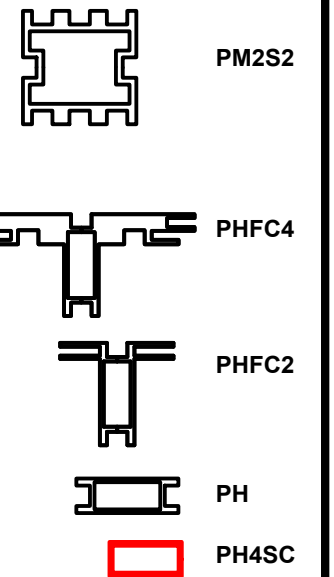

**Fabric 'A' Assembly**

**HYBRID PRO RENTAL KIT**

Title: SET-UP INSTRUCTIONS

Code	#	Description
GRAPHIC D	1	110 9/16" (H) X 39" (W) X 30MM TUBING - FABRIC STRUCTURE- ATTA

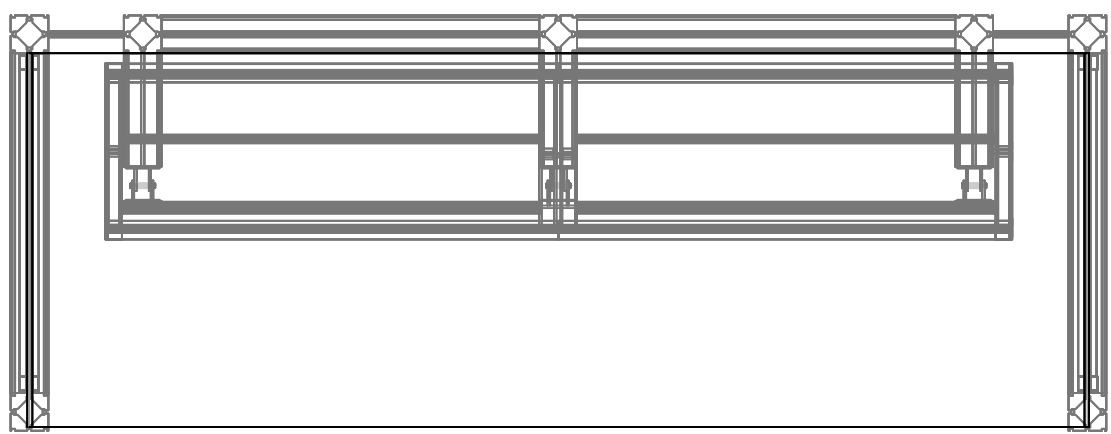



1. Redesign of this exhibit without approval by manufacturer may result in dangerous and unsafe structures. Manufacturer disclaims any responsibility for redesigned exhibits it does not approve in writing.

2. Parts and components such as panels and extrusions are manufactured to metric sizing. Where ever possible sizes have been noted in feet and inches as well as in metric. Below is the imperial to metric sizing table as reference. "Nominal" refers to approximate size.

- |                    |                                 |
|--------------------|---------------------------------|
| 2400mm = (94 1/2") | Phone Line / Fax                |
| 2100mm = (82 5/8") | Internet connection             |
| 1800mm = (70 7/8") | Outlet                          |
| 1500mm = (59")     | Main Drop (point of distrution) |
| 1200mm = (47 1/4") |                                 |
| 900mm = (35 1/2")  |                                 |
| 600mm = (23 5/8")  |                                 |
| 300mm = (11 7/8")  |                                 |
- Wire running under carpet

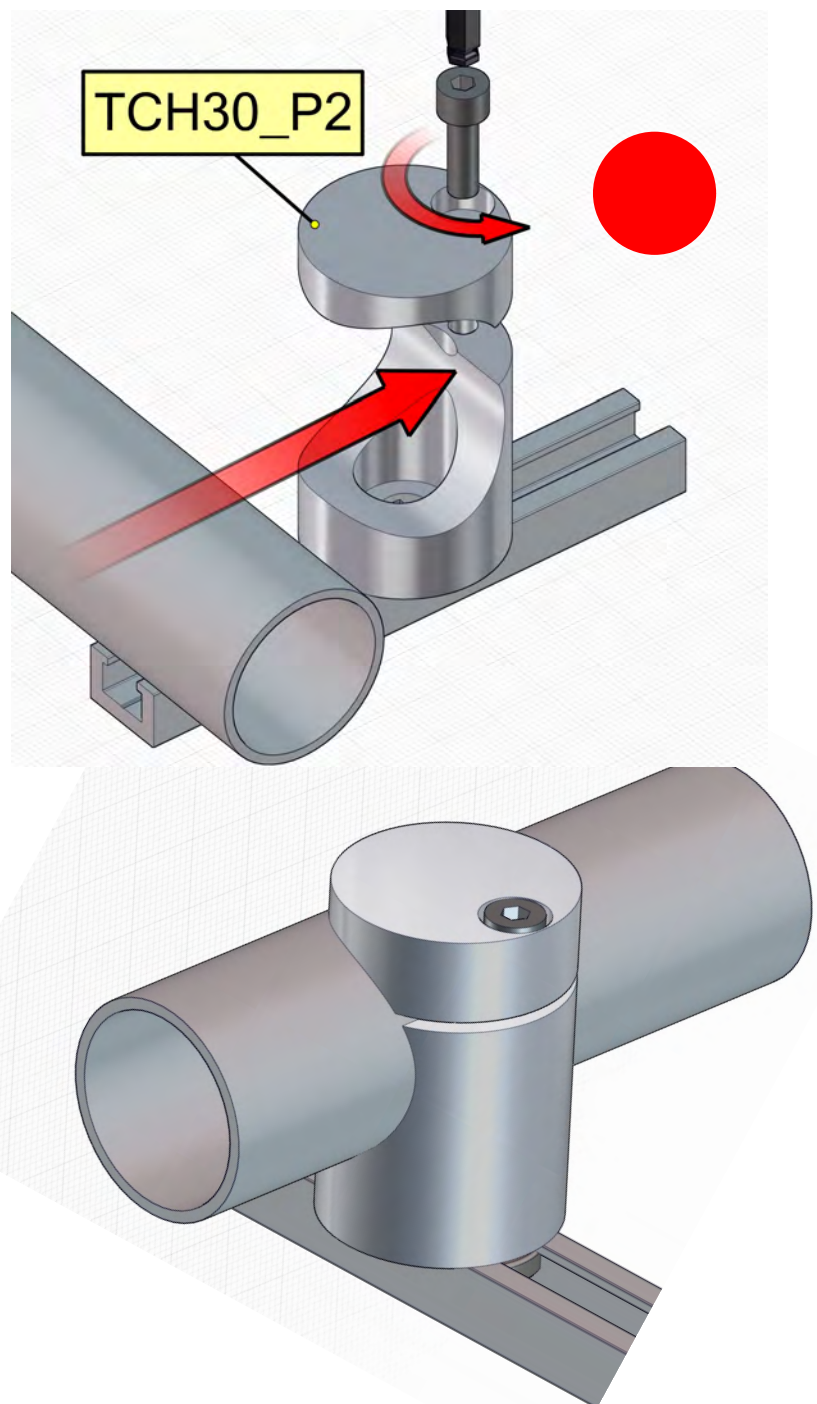
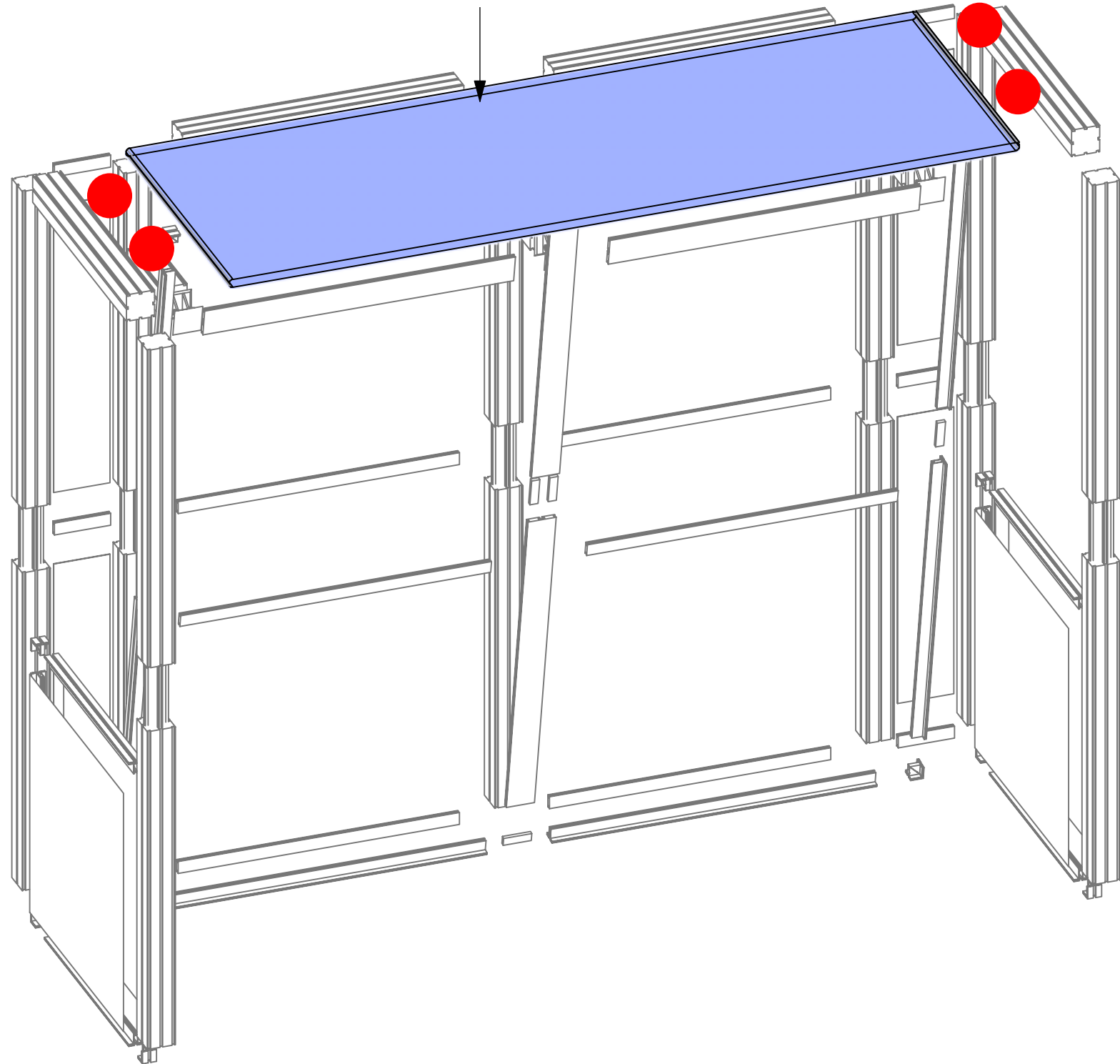
**GRAPHIC D**

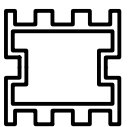
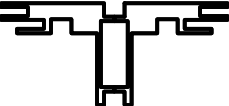
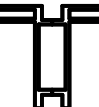

-  PM2S2
-  PHFC4
-  PHFC2
-  PH
-  PH4SC

**HYBRID PRO RENTAL KIT**

Title: SET-UP INSTRUCTIONS

# **PACKING INSTRUCTIONS**





1

(1) STEAMER, (2) HARDWARE BOXES

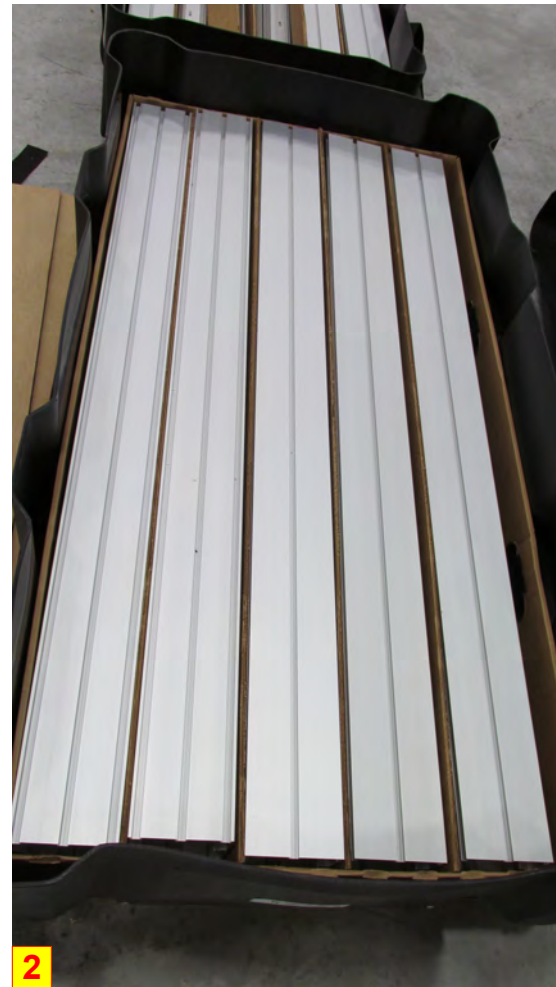

2

(5) R15



3

(2) R32, (4) R33, (4) R18, (8) R28



4

(4) R30, (4) R29



HARDWARE BOX



HARDWARE BOX

# CASE # 1

<b>LEGEND</b>		GREY FOAM FOLDED TO FILL EMPTY SPACES OR USED AS PROTECTION
		1/8" CARDBOARD SPACER (PUT IN BETWEEN EVERY PANEL)
		DIVIDER
		1/4" WHITE FOAM (USED AS PROTECTION DOOR PANELS W/ LOCKS)



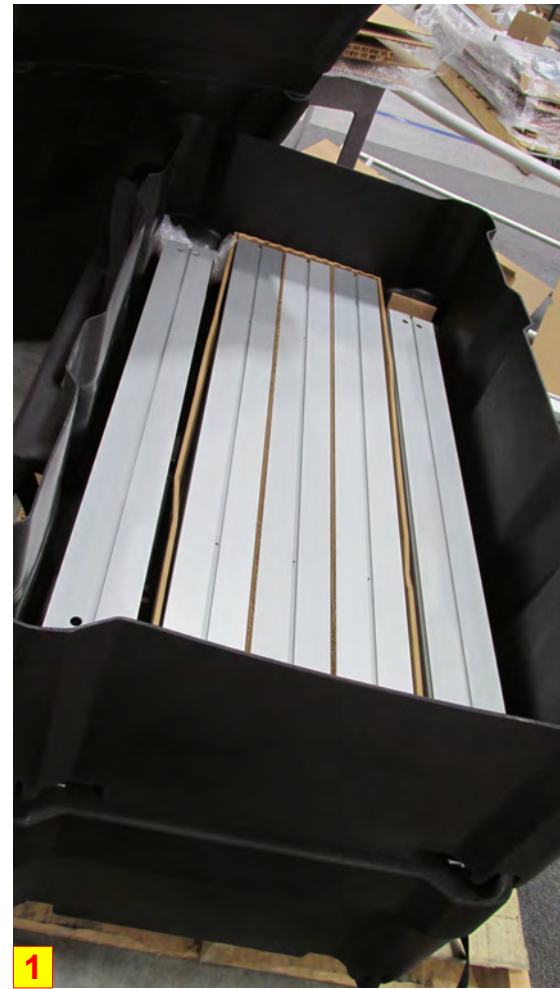

(2) R34, (3) R15



(4) R62, (5) R15



(1) R15, (2) R35, (3) R36, (3) R13



(1) STRUCTURE

# CASE # 2

<b>LEGEND</b>		GREY FOAM FOLDED TO FILL EMPTY SPACES OR USED AS PROTECTION
		1/8" CARDBOARD SPACER (PUT IN BETWEEN EVERY PANEL)
		DIVIDER
		1/4" WHITE FOAM (USED AS PROTECTION DOOR PANELS W/ LOCKS)

